

How to secure steel coils in 20'gp container

General

Following points to be observed for securing coils:

- correct length of the cradle for weight distribution
- blocking against side and length shifting in floor height above the bedding
- lashing in four direction or several coils together to one full block

The below securing guideline is valid for all types of coils. Coils can be loaded eye to the sky, eye to the door or eye to the side. Usually loading coils eye to the sky is not so problematic, as the coil weight is not so high and the weight is better distributed. Loading eye to the side is the common method and usually used for the heavy coils. Therefore the first chapter explain stuffing coils eye to the side. All guidelines like weight distribution, bedding, blocking and lashing have to be followed by all stuffing methods (eye to sky and eye to door). At the end some special chapters added for loading coils eye to the door.

Part A coil stowed with eye to the side

1. Preparation of cradle

Build a cradle which meets the following requirements:
Length (a) in cm to be calculated: coil weight in kg / 48 kg/cm. (Limit: 4,8t per meter = 48kg per cm) or longer.

Maximum free end b on each side depends on the thickness of used square timber.

10x10cm: max 50cm.

15x15cm: max 75cm.

20x20cm: max 100cm

25x25cm: max 125cm.

30x30cm: max 150cm.

If hard wood is used above

value can be extended by 10cm. Hapag-Lloyd do not recommend the use of timber with 25x25cm or higher and also hard wood because of environmental reasons.

If not possible to meet these requirements, coils are too heavy for loading on timber bedding. Then steel bedding or other container types like flatracks required. Pls contact first your sales office, when you intend to ship heavier coils.

In summery of above requirement, coils of more than 15t can not be shipped in 20' standard container. If somebody insists to ship heavier coils, stuffing method has to be agreed with special cargo department of Hapag-Lloyd case by case.

The coils have always to be place in the container with the bedding in length direction. The bedding needs to have minimum 2 timbers in one-piece, placed as fare as possible

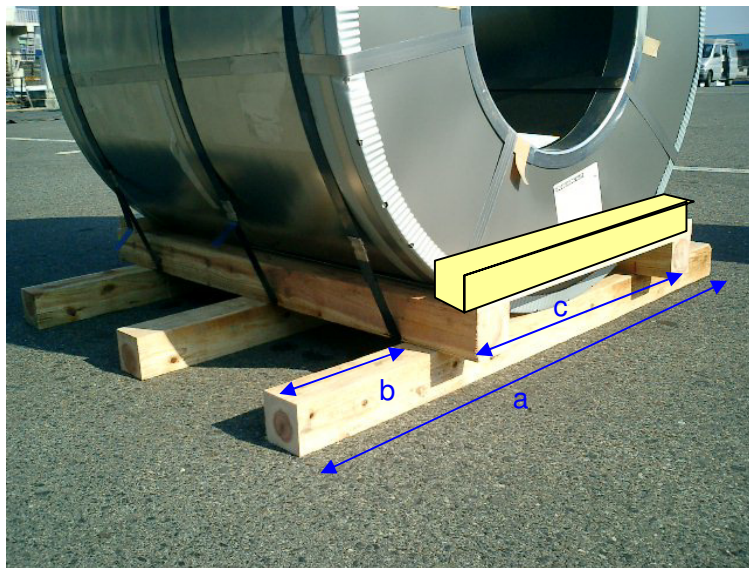

to the outward position, close to the container side walls. Additional beddings below the middle of the coils are not a requirement from the container owner, but can be added.

Example1: coil weight: 7650kg, $c=65\text{cm}$ Result: $a=160\text{cm}$, $b= (160-65\text{cm})/2=48\text{cm}$ square .timber 160x10x10cm possible.

Example2: coil weight: 9960kg, $c=75\text{cm}$ Result: $a=208\text{cm}$, $b= (208-75\text{cm})/2=67\text{cm}$ square .timber 210x15x15cm possible.

2. Position inside the container

A single coil should be placed in the middle in length and athwart direction inside the container. When two coils are loaded in the container, it should be avoided to place both together in the middle. Place one as far as possible to the end wall and the other as close as possible to the door side. The space to door and end wall required for blocking and securing shall of course remain.

3. Blocking

Task of the blocking is to prevent sliding of coils in length and athwart direction. It needs to be taken in account, that the door can **not** take any force and the container walls are very soft. Thus the blocking is to be spread over a large surface and in the lowest possible height.

Blocking to the side: Timber (a) already there from the cradle, see chapter 2. Then two pieces (b) to be placed between (c) and (a), with a distance in between as wide as possible. To keep all pieces (b) and (c) in the same height, min. 4 pieces supports (d) to be placed below and nailed together. It is important that (b) do not touch the containers side wall.

Side view:

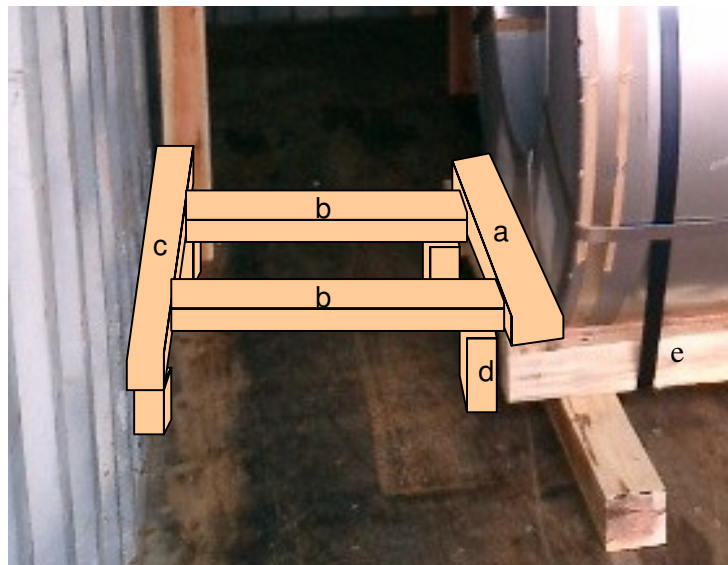
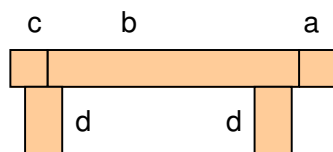

Same patter to be done on the other side.

Blocking in length direction to be placed against athwart timber (e) on which the coil rest.

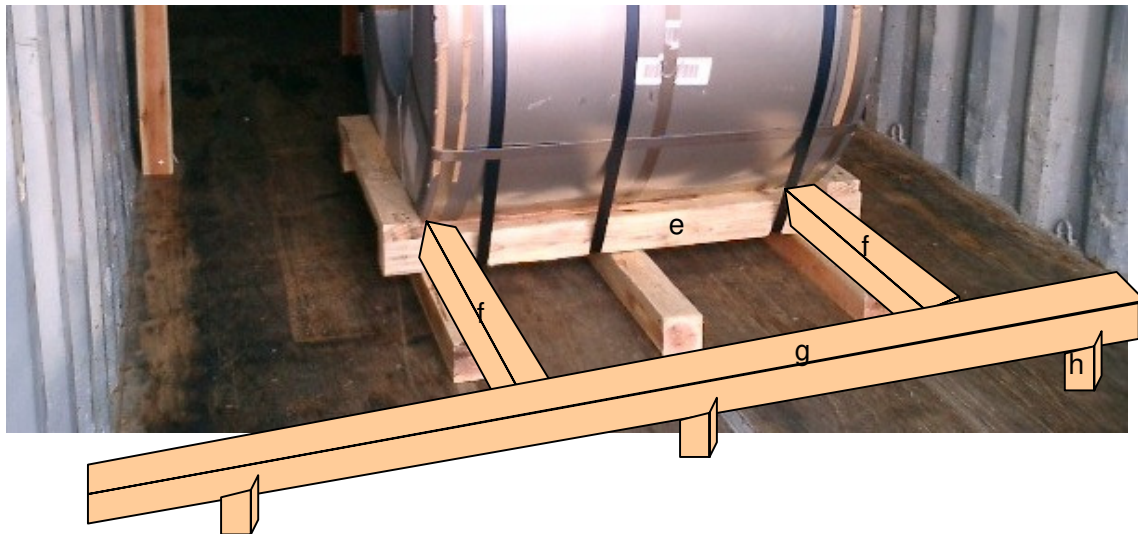

Both pieces (f) need to be placed between (e) and (g), all in the same height. Best to lay pieces (f) on the bedding and put the timber (g) on top of supports (h) with the same height as the bedding. Square timber (g) to be set with its ends into the corrugated side walls of the container.

Blocking between 2 coils simple to be done with two pieces (f) between (e) of each coil. Blocking to end wall of the container can be done with (g) fixed into the corrugated side walls or touching the end wall over the full width, same pattern as blocking to the side (c).

There are special requirements for rail shipment. A stronger blocking in length direction is required by the rail companies. To place a timber (g) in between the corrugated sidewalls is not accepted. Therefore the blocking is to be set against the corner posts and end wall of the container and into the recess of the corner post at the door side.

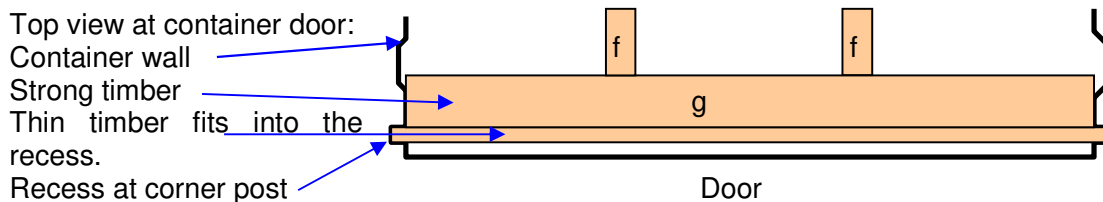

One 4X6" buffer in front of two 2X6" boards

Picture left side shows example of blocking lengthwise with use of the recess in corner post at door side.

Finally we can say that blocking is possible without nailing to the container floor and any wedges. Nails can be used to keep the wood constructions together, but no forces should be brought to the nails. Also the wedges can be used as bedding of the coil, but not for blocking.

4. Lashing

Aim of the lashing is to secure against tipping. The height on which the lashing is fixed to the coil is usually below the middle. Therefore it is only workable when the coils are blocked in floor height as well. The lashing of each coil needs to be done by 4 lashings. Each starts and ends on the same point. As lashing material can be used best steel straps, but also nylon belts with edge protections or steel wires.

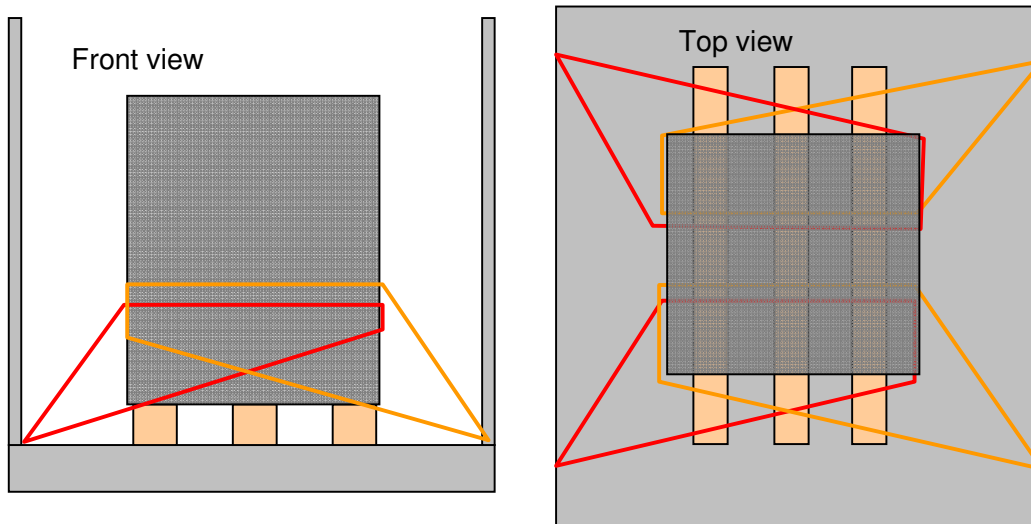

As the lashing eyes of a container can take only 1-2t, the strength of lashing material need not more than 2t.

5. Example

Here you can see one picture of good securing a steel coil with eye to the side.



For heavy, high and thin steel coils it is useful to add a blocking to the side wall in a higher position.



Part B coil stowed with eye to the door

Lay out the bedding (brown) and blocking to the side walls (yellow). The distance between both square timbers of the bedding should be as wide as possible, but only so far apart that the steel coil will have no contact in the middle with the floor of the container. Use stronger square timber to reach a wider distance. Length of the bedding (a) depends on the weight of the coil and will be calculated in cm: coil weight in kg / 48 kg/cm. (Limit: 4,8t per meter = 48kg per cm) or longer. At least the bedding length should be 20cm longer (10cm each side) than length of the coil to place on this bedding on each end timber for blocking in length direction. Maximum free ends (b) have the same limits as written in Part A.

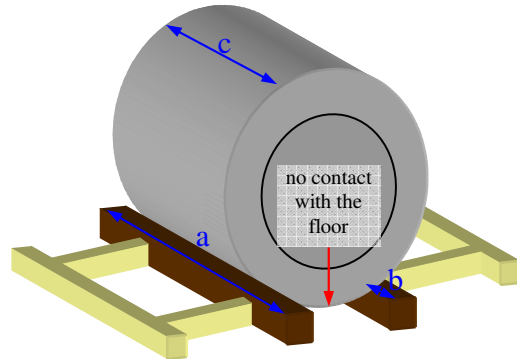

The blocking in length direction is to be done same way as written in Part A. Place a timber (d) athwart, one timber (f) athwart into corrugates side walls or recess of corner posts at the door and add two timber (e) as connection in between. Below timber (f) small supports required to archive same height over the whole arrangement. Blocking in length direction is to be placed on both sides of each coil.

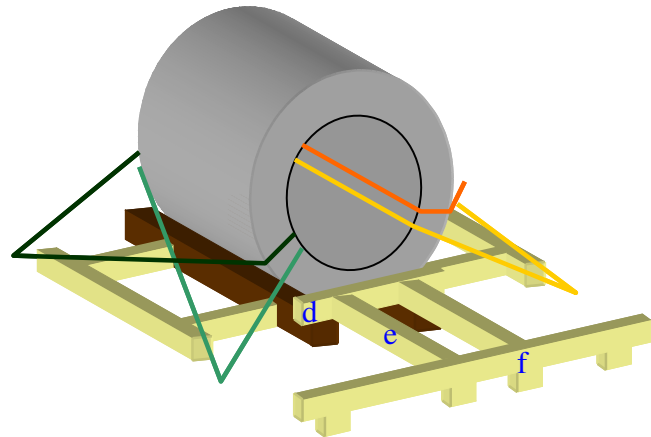

Finally the coil is to be secured by 4 nylon belts, each from each corner, like a closed circle.

For any further questions regarding this proposal please contact:
 Ralph Schubert,
 Phone: +49 40 3001 4453
 Email: Ralph.schubert@hlag.com