

Hapag-Lloyd East-West Service Network 2025



Trade Highlights and Service Maps – Suez Canal

October 2024 | Hamburg



Agenda

A. Hapag-Lloyd East-West Service Network at a Glance	2
B. Trade Overview Asia - Europe	7
C. Trade Overview Atlantic	28
D. Trade Overview Transpacific	52
E. Trade Overview Middle East	73
F. Overview Shuttle Network and Intra Regional Trades	87

Gemini Cooperation will enable us to offer significantly higher quality liner services to our customers

Our value proposition ...



RELIABILITY



CONNECTIVITY



SUSTAINABILITY

... your benefit

- Enable >80% on-time delivery of your cargo
- Link all your relevant markets with fast and resilient transit times
- Accelerate the decarbonization of your supply chains

In case of a re-opening of the Suez Canal the Gemini Cooperation will be ready to adapt fast to the already published Suez Network design

- Due to the **on-going conflict in the Red Sea** a contingency **Cape Network** has been set-up
- As **like-minded partners** we have **jointly** and **efficiently** prepared options to ensure a smooth start of the Cooperation, with **flexibility** to adapt
- Both networks will **deliver on reliability and connectivity**, powered by the **innovative Hub-and-Spoke Network**
- Both networks ensure **broad port coverage** with an **efficient mainliner network, dedicated shuttle services** and complementing **feeder services**
- Decision** on final network option for launch of Gemini Cooperation **to be communicated in October**



A HL East-West Suez Network scenario will offer a broad coverage across key trades complemented by intra-regional connectivity



... and will be an integral part of Hapag-Lloyd's overall network of in total around 120 services globally

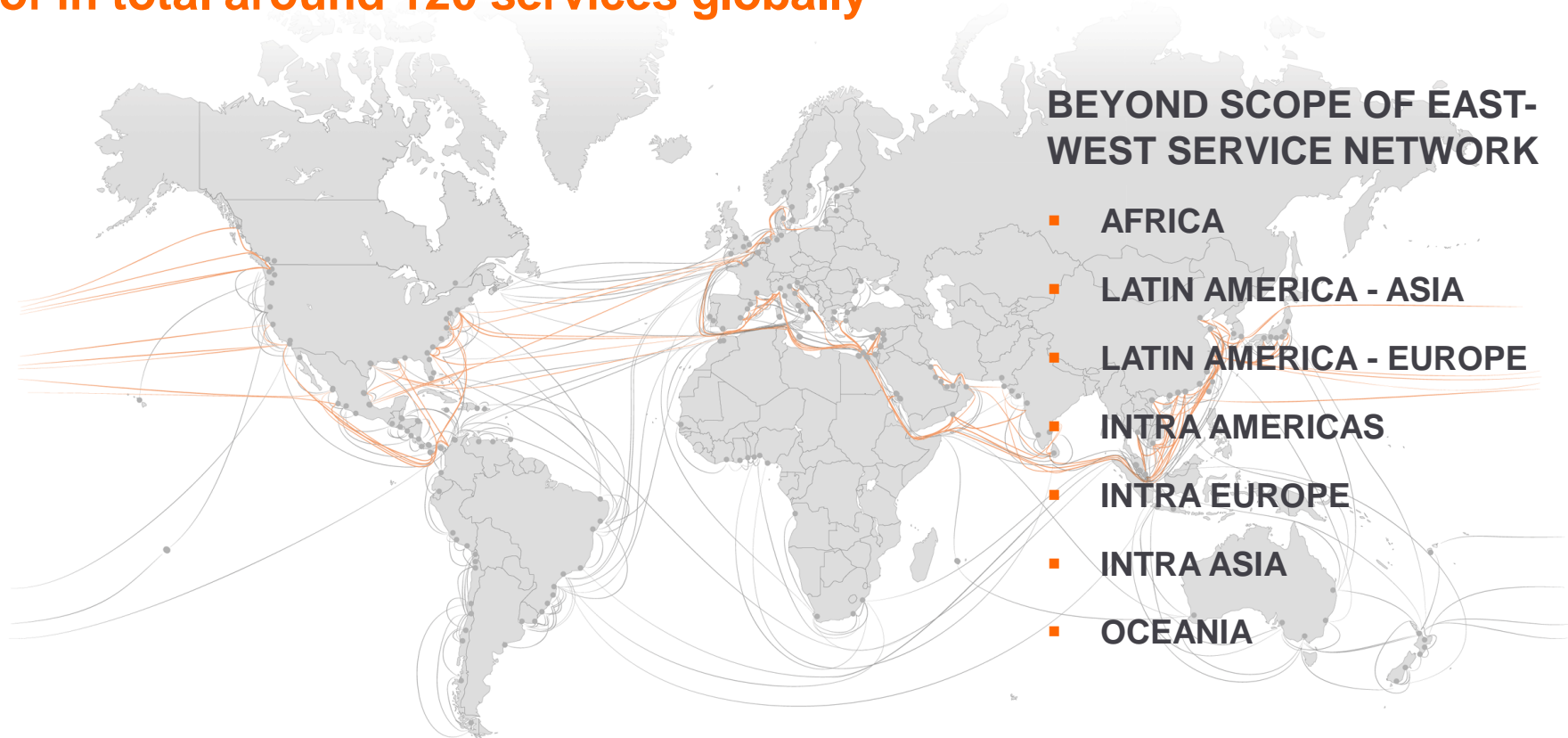

Agenda

- | | | |
|-----------|--|----------|
| A. | Hapag-Lloyd East-West Service Network at a Glance | 2 |
| B. | Trade Overview Asia - Europe | 7 |
| C. | Trade Overview Atlantic | 28 |
| D. | Trade Overview Transpacific | 52 |
| E. | Trade Overview Middle East | 73 |
| F. | Overview Shuttle Network and Intra Regional Trades | 87 |

Asia - Europe

Highlights of our Asia - Europe services

- Comprehensive Asia product with unrivalled reliability
- Delivering robust, on-time and weekly service schedules to our customers
- Benefit from a broad coverage of key markets through dedicated shuttle network in Asia and Europe offering seamless connections
- Enhanced coverage allowing further connections to key markets, e.g. Asia to Africa and Europe to Oceania
- Seamlessly connected shuttle network at mostly owned or controlled hubs
- New connections, e.g. from / to Malaysia and from / to Koper (as a gateway into Central Europe)

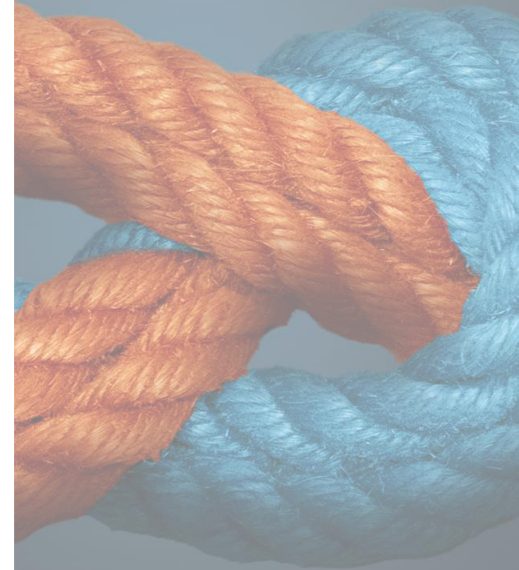

Asia - Europe

Our Asia-Europe service in numbers

KEY FACTS

7

Services

72

Vessels

8

Ø Calls per service

18 TTEU

Ø Vessel size

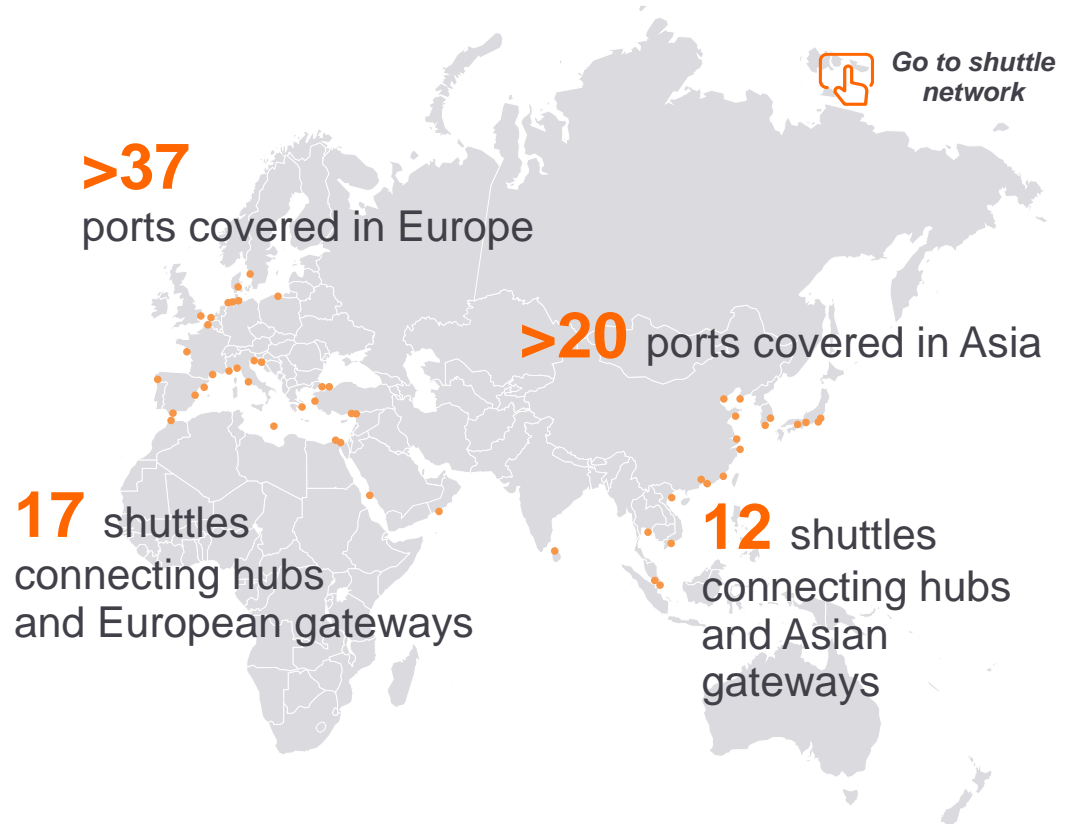

Asia - Europe

Port coverage on our Asia - North Europe services



Asia - Europe

Our Asia - North Europe services at a glance

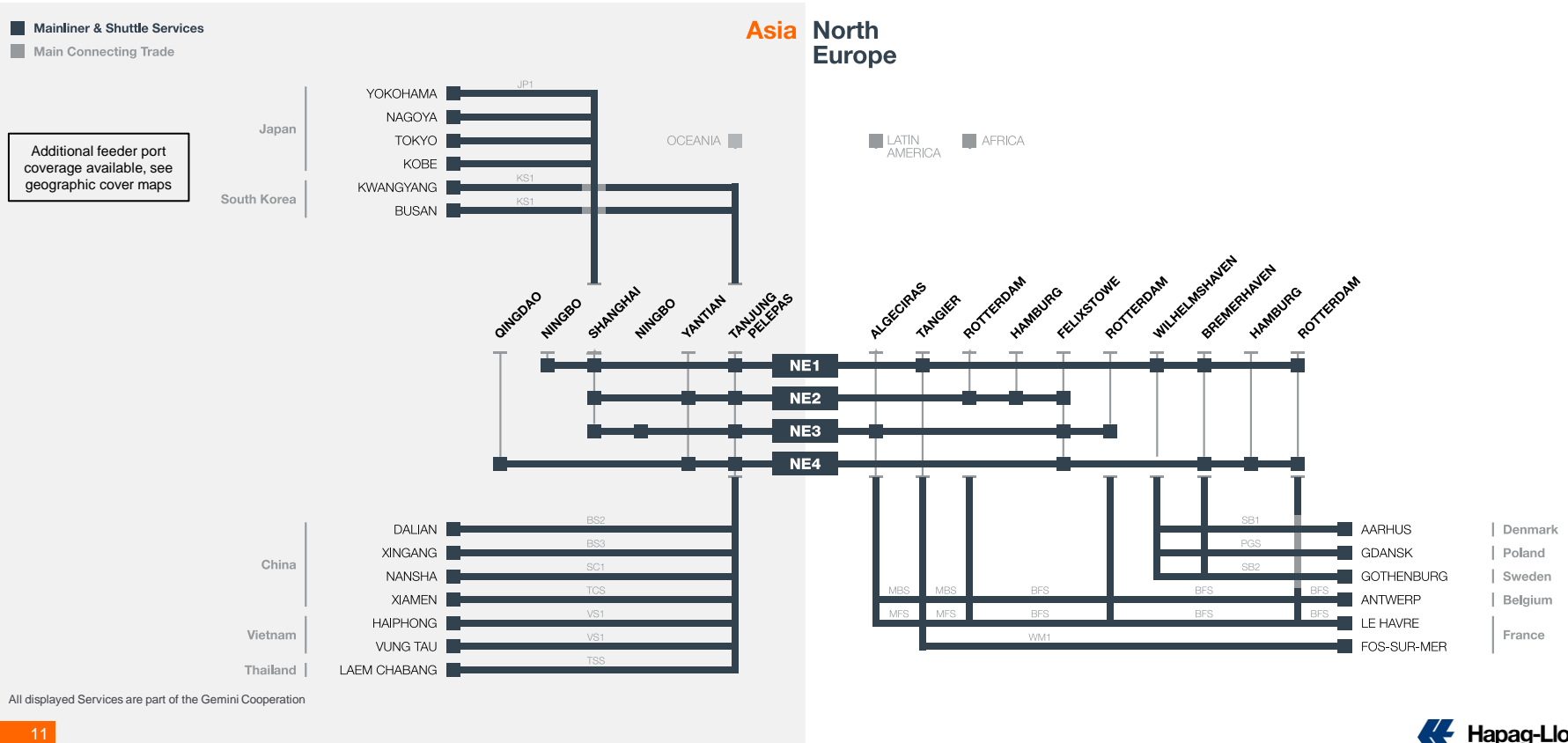

Asia - Europe

Our North Europe - Asia services at a glance

■ Mainliner & Shuttle Services

Additional feeder port coverage available, see geographic cover maps

North Europe Asia

AFRICA ■ LATIN AMERICA

MIDDLE EAST ■ OCEANIA

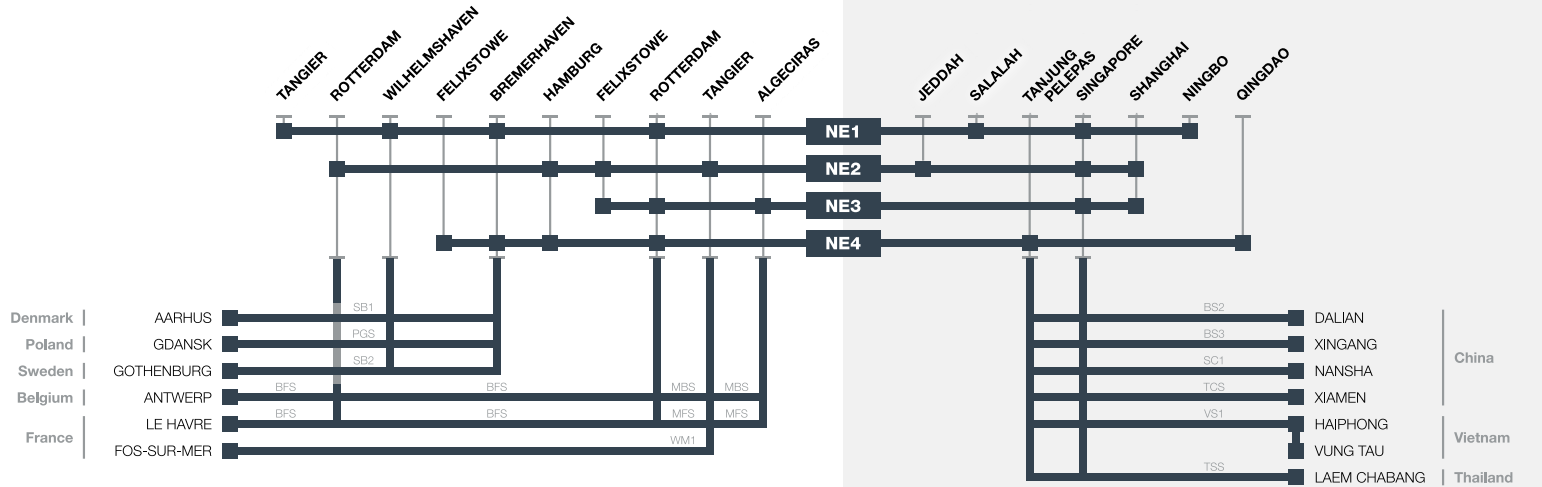

All displayed Services are part of the Gemini Cooperation

Asia - Europe

Service Profile NE1

Gemini Cooperation Service



KEY SERVICE VALUE PROPOSITION

- Key service from Central China to North Europe via the Suez Canal
- Eastbound service from Germany, Scandinavia/Baltic to Central China and connection to Southeast Asia and Oceania
- Serving the markets from North and South Europe to the Middle East with a direct connection to Salalah (OM)

IMPORTANT CONNECTIONS

- Shuttles via Shanghai (CN) for Japanese cargo to and from Germany, Scandinavia and the Baltic
- Shuttles via Tanjung Pelepas (MY) and Singapore (SN) for further Southeast Asia and South China destinations as well as Korea
- Connection to Scandinavia and the Baltics via Wilhelmshaven (DE)
- Tangier (MA) connects the remaining Mediterranean

Asia - Europe

Service Profile NE2

Gemini Cooperation Service

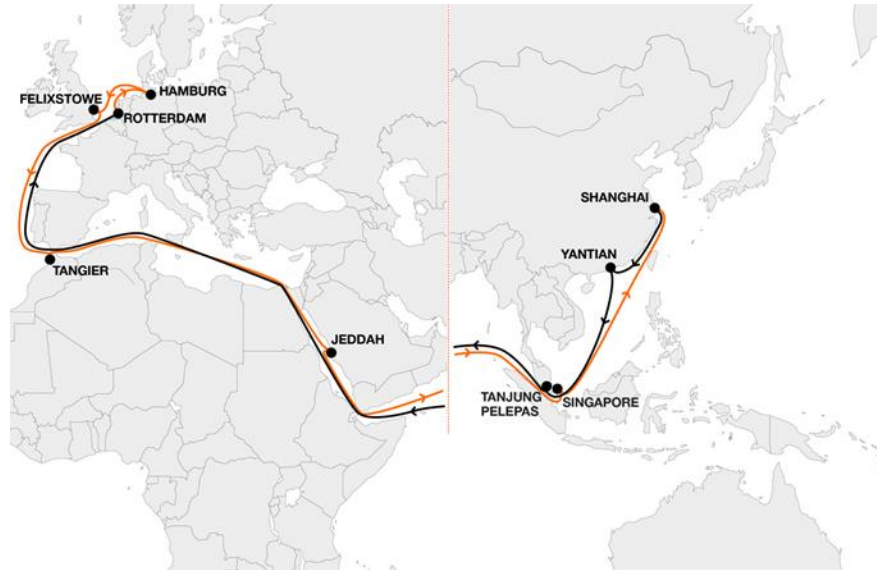

KEY SERVICE VALUE PROPOSITION

- Key service to connect Hamburg (DE) as additional gateway from Central and South China to North Europe via the Suez Canal
- Eastbound service with connection from the UK to Central China, Southeast Asia and Oceania
- Serving the markets from Europe to the Middle East with a direct connection to Jeddah (SA)

IMPORTANT CONNECTIONS

- Shuttles via Shanghai (CN) connect Japanese cargo to Rotterdam (NL) and Hamburg (DE)
- Shuttles via Rotterdam (NL) connect to Antwerp (BE) and Le Havre (FR)
- Tangier (MA) connects the remaining Mediterranean
- Mainline and shuttle connections to Ningbo (CN), Southeast Asia & Korea through Tanjung Pelepas (MY) and Singapore (SN)

Asia - Europe

Service Profile NE3

Gemini Cooperation Service



KEY SERVICE VALUE PROPOSITION

- Key service from Central China to South and North Europe via the Suez Canal
- Eastbound service from the Netherlands to Central China, Southeast Asia and Oceania

IMPORTANT CONNECTIONS

- Shuttles via Shanghai (CN) connect Japanese cargo to Felixstowe (UK)
- Shuttles to Antwerp (NL), Le Havre and Fos-sur-Mer (FR) via Algeciras (ES)
- Multiple connections from South China, Southeast Asia and Korea through shuttles via Tanjung Pelepas (MY) and Singapore (SN)

Asia - Europe

Service Profile NE4

Gemini Cooperation Service



KEY SERVICE VALUE PROPOSITION

- Key service from Central and South China to North Europe via the Suez Canal
- Eastbound service from Germany and the Netherlands to Southeast Asia
- Additional gateway option for Hamburg (DE) and the UK next to the NE2

IMPORTANT CONNECTIONS

- Shuttles via Tanjung Pelepas (MY) allow multiple westbound connections from Shanghai (CN), Ningbo (CN), Southeast Asia and Korea
- Connection from Hamburg (DE), Bremerhaven (DE) and Rotterdam (NL) to Oceania via Singapore
- Connection to Scandinavia and the Baltics via Bremerhaven (DE)

Asia - Europe

Port coverage on our Asia - South Europe services



Asia - Europe

Our Asia - South Europe services at a glance

- Mainliner & Shuttle Services
- Main Connecting Trade

Additional feeder port coverage available, see geographic cover maps

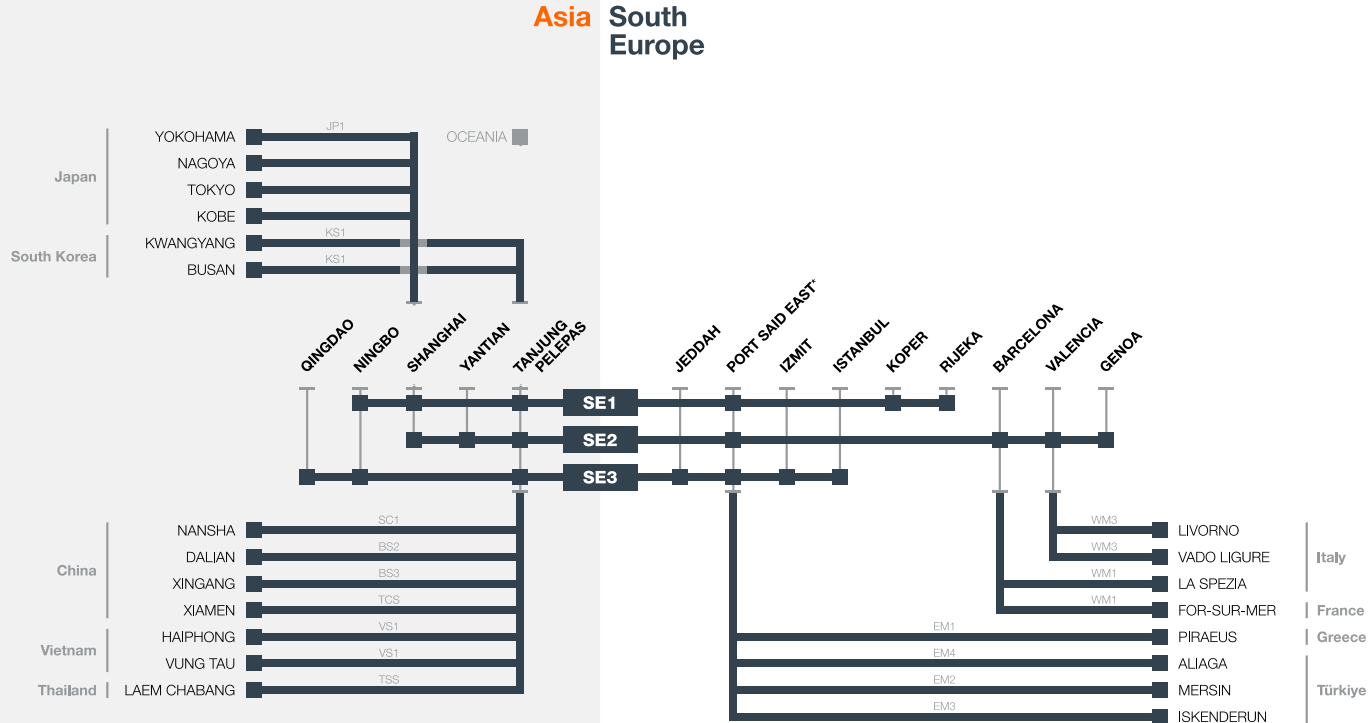

All displayed Services are part of the Gemini Cooperation
 *Certain Port Said East EB calls will be shifted to Damietta during 2025

Asia - Europe

Our South Europe - Asia services at a glance

- Mainliner & Shuttle Services
- Main Connecting Trade

Additional feeder port coverage available, see geographic cover maps

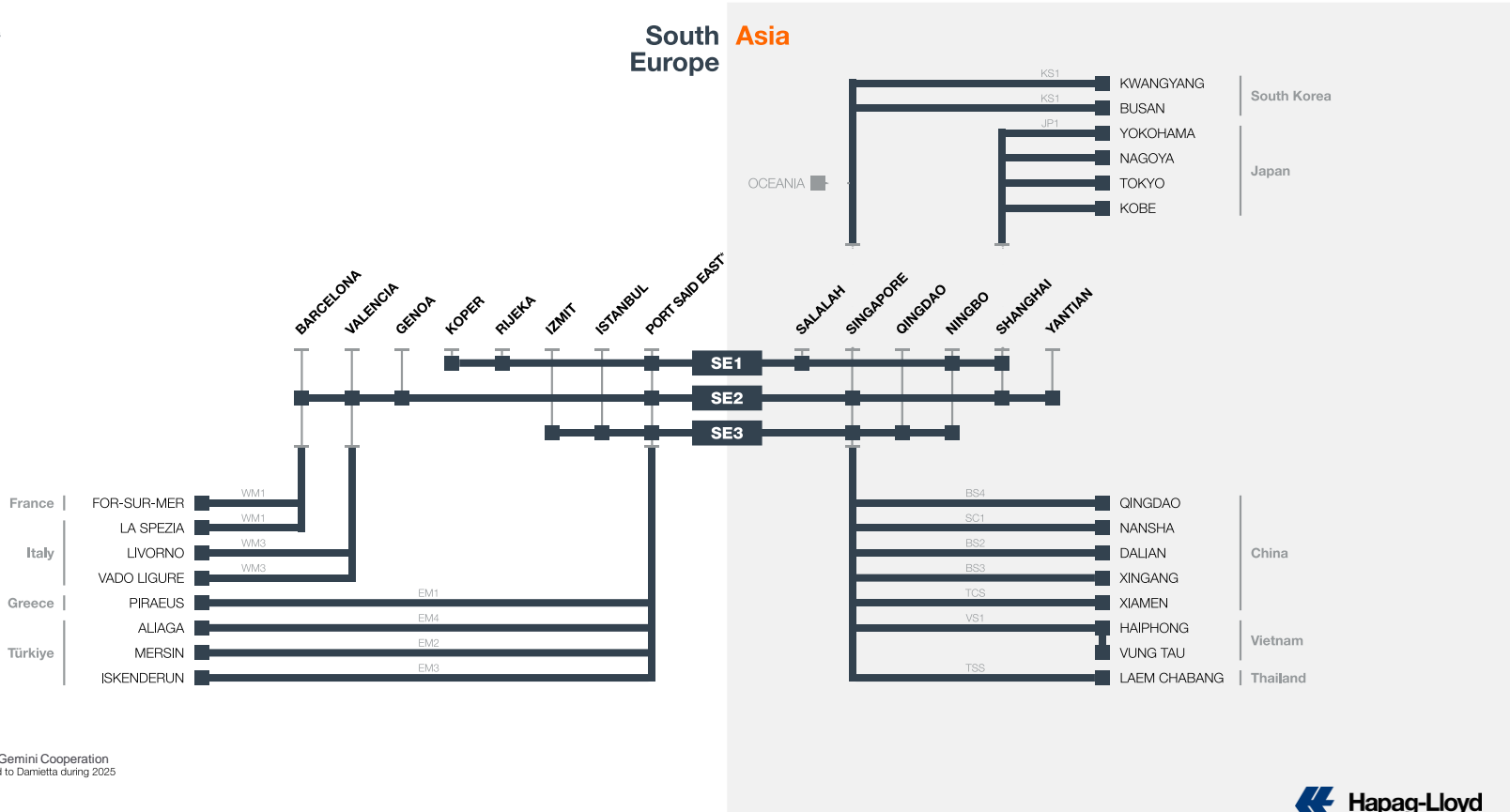

All displayed Services are part of the Gemini Cooperation
 *Certain Port Said East EB calls will be shifted to Damietta during 2025

Asia - Europe

Service Profile SE1

Gemini Cooperation Service

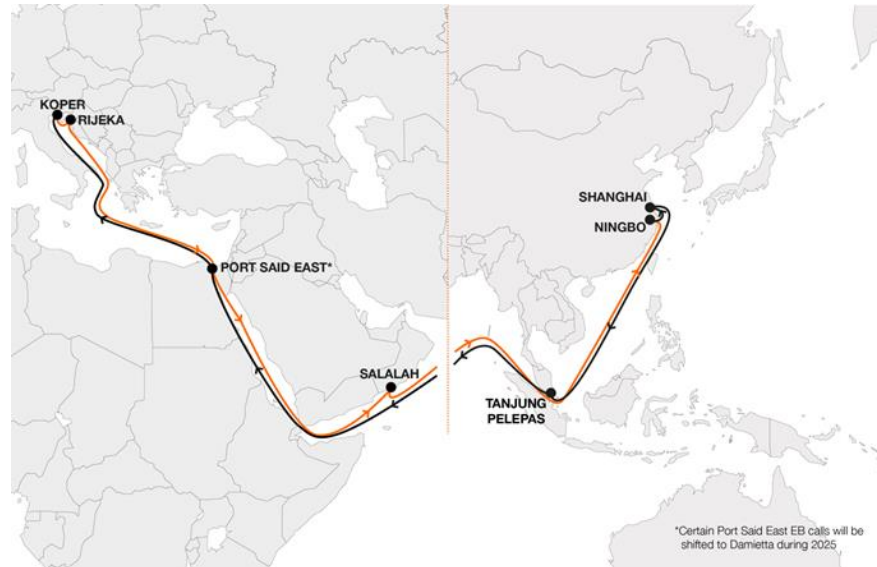

KEY SERVICE VALUE PROPOSITION

- Key service from Koper (SI) and Rijeka (HR) as gateways to Central European markets from Central China via the Suez Canal
- Serving the markets from the Middle East with direct connections to Salalah (OM) and Port Said East (EG)

IMPORTANT CONNECTIONS

- Shuttles via Shanghai (CN) connect Japanese cargo
- Shuttles via Tanjung Pelepas (MY) allow multiple westbound connections from Asia
- Port Said East (EG) enables fast and efficient transit from and to Türkiye, Levant and Greece plus Black Sea markets covered via additional feeders

Asia - Europe

Service Profile SE2

Gemini Cooperation Service



KEY SERVICE VALUE PROPOSITION

- Key service from South Europe as gateway to European markets from Central and South China via the Suez Canal
- Eastbound service to export markets from Spain and Italy to Central and South China, Southeast Asia and Oceania via Singapore (SG)

IMPORTANT CONNECTIONS

- Shuttles via Shanghai (CN) connect Japanese cargo to Spain and Italy
- Shuttles from Port Said East (ES) connect to Turkey
- Shuttles via Valencia (ES) cover additional Italian ports
- Shuttles via Tanjung Pelepas (MY) and Singapore (SN) allow multiple connections, e.g. Xiamen (CN), Vung Tau (VN) and Korea

Asia - Europe

Service Profile SE3

Gemini Cooperation Service

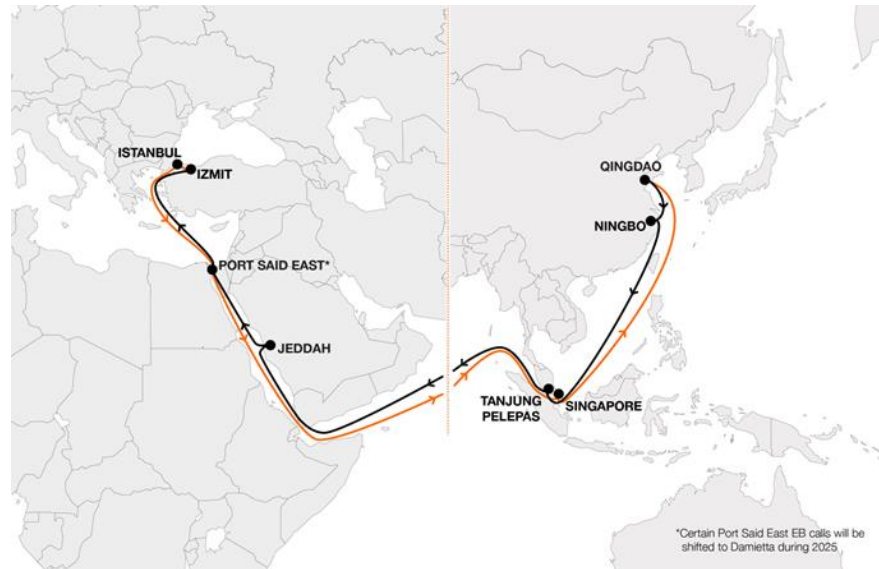

KEY SERVICE VALUE PROPOSITION

- Key service to Türkiye, as gateway to Europe, from Qingdao (CN) and Ningbo (CN) via the Suez Canal
- Serving the markets from the Middle East with direct connections to Port Said East (EG) and Jeddah (SA)

IMPORTANT CONNECTIONS

- Shuttles via Tanjung Pelepas (MY) connect Korean cargo to Türkiye
- Shuttles via Tanjung Pelepas (MY) and Singapore (SN) allow multiple connections to e.g. Nansha (CN) or Haiphong (VN)
- Port Said East (EG) and Jeddah (SA) enable fast and efficient transit from and to Türkiye, Levant and Greece plus Black Sea markets covered via additional feeders

Agenda

A.	Hapag-Lloyd East-West Service Network at a Glance	2
B.	Trade Overview Asia - Europe	6
	Asia-Middle East	24
C.	Trade Overview Atlantic	20
D.	Trade Overview Transpacific	30
E.	Trade Overview Middle East	43
F.	Overview Shuttle Network and Intra Regional Trades	51

Middle East

Our Asia to Middle East services at a glance

■ Mainliner & Shuttle Services

Additional feeder port coverage available, see geographic cover maps

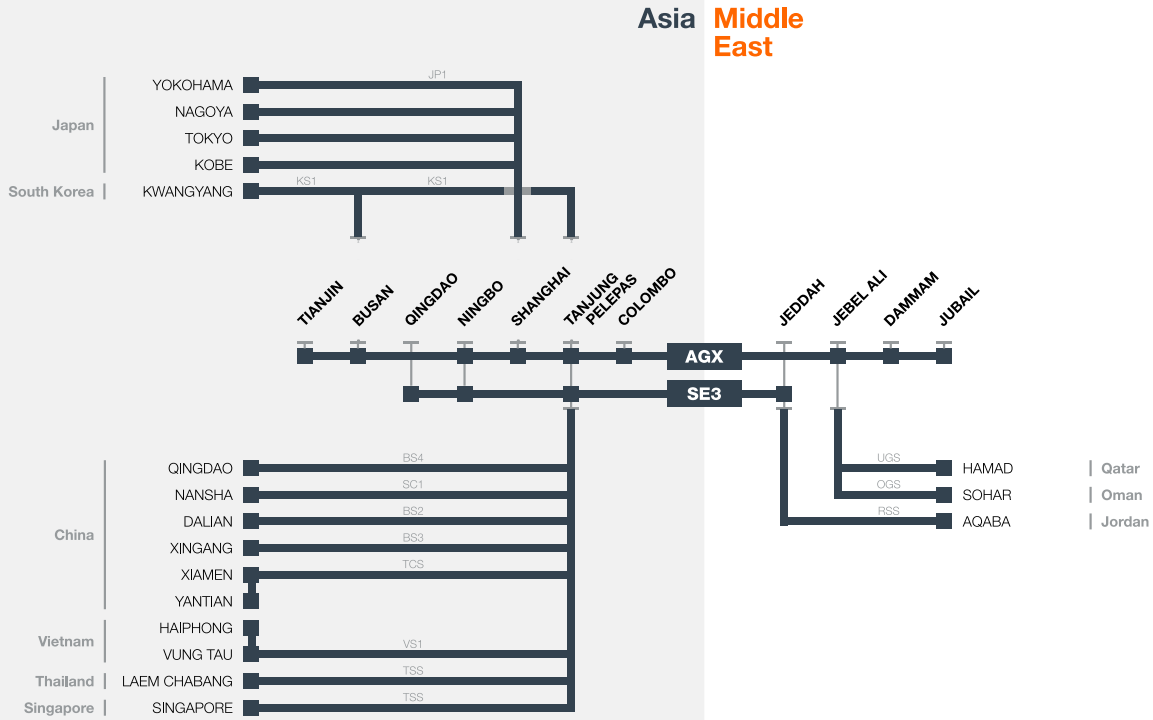

All displayed Services are part of the Gemini Cooperation

Middle East

Our Middle East to Asia services at a glance

- Mainliner & Shuttle Services
- Main Connecting Trade

Additional feeder port coverage available, see geographic cover maps

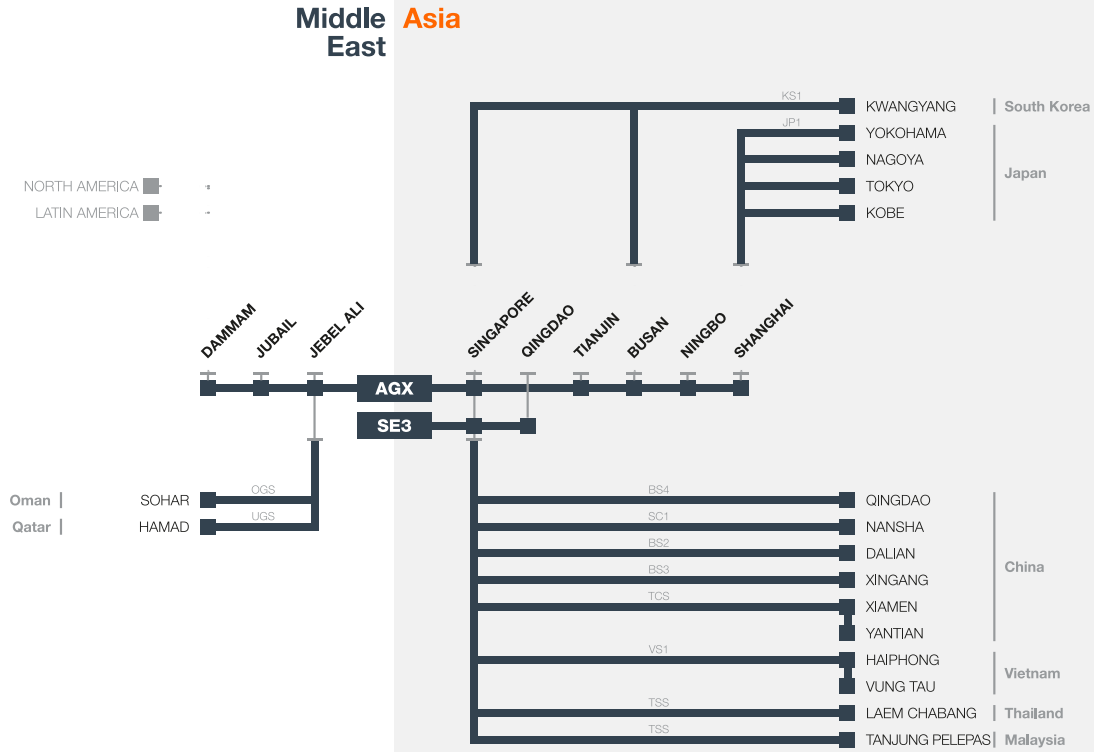

All displayed Services are part of the Gemini Cooperation

Asia-Middle East

Service Profile AGX

Gemini Cooperation Service



KEY SERVICE VALUE PROPOSITION

- Key service from Busan (KR), Tianjin (CN), Shanghai (CN) and Ningbo (CN) to the Arabian Gulf
- Eastbound service from the Arabian Gulf to East Asia and Oceania via Singapore (SG)

IMPORTANT CONNECTIONS

- Shuttles from Jebel Ali (AE) into the Arabian Gulf
- Shuttles via Tanjung Pelepas (MY), Singapore (SN) and Shanghai (CN) allow multiple connections from Southeast Asia and Oceania

Agenda

- | | | |
|-----------|--|-----------|
| A. | Hapag-Lloyd East-West Service Network at a Glance | 2 |
| B. | Trade Overview Asia - Europe | 7 |
| C. | Trade Overview Atlantic | 28 |
| D. | Trade Overview Transpacific | 52 |
| E. | Trade Overview Middle East | 73 |
| F. | Overview Shuttle Network and Intra Regional Trades | 87 |

Atlantic

Highlights of our Atlantic services

- Highly reliable and resilient Atlantic network with competitive transit times
- Strong product with excellent coverage connecting North and South Europe with the USA and Mexico
- Prime product out of North Europe to the US East and Gulf Coast
- Continued dedicated Mexico services out of North and South Europe
- Strong connectivity from the West Mediterranean via Tangier to the US East Coast
- Efficient US West Coast coverage via Cartagena
- Continued Atlantic Canada and East Mediterranean coverage through Hapag-Lloyd services outside of the Gemini Cooperation scope

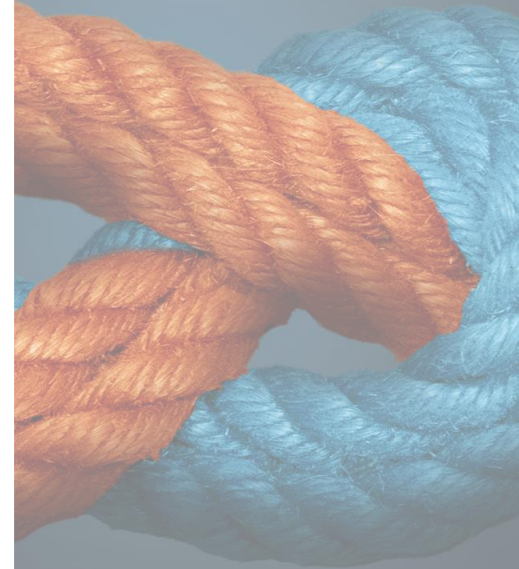

Atlantic

Our Atlantic service in numbers

KEY FACTS

13 + 1*

Services

90

Vessels

8

Ø Calls per service

5.4 TTEU

Ø Vessel size

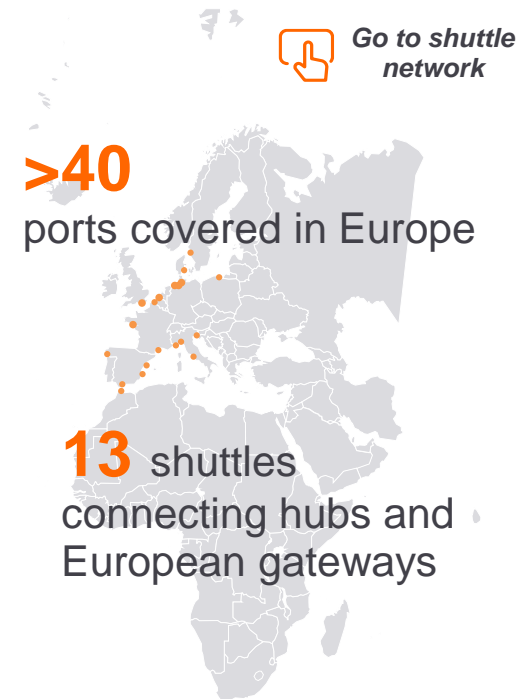

Atlantic

Port coverage on our North America - North Europe services



Atlantic

Our North Europe to North America services at a glance

■ Mainliner & Shuttle Services

Additional feeder port coverage available, see geographic cover maps

North Europe North America

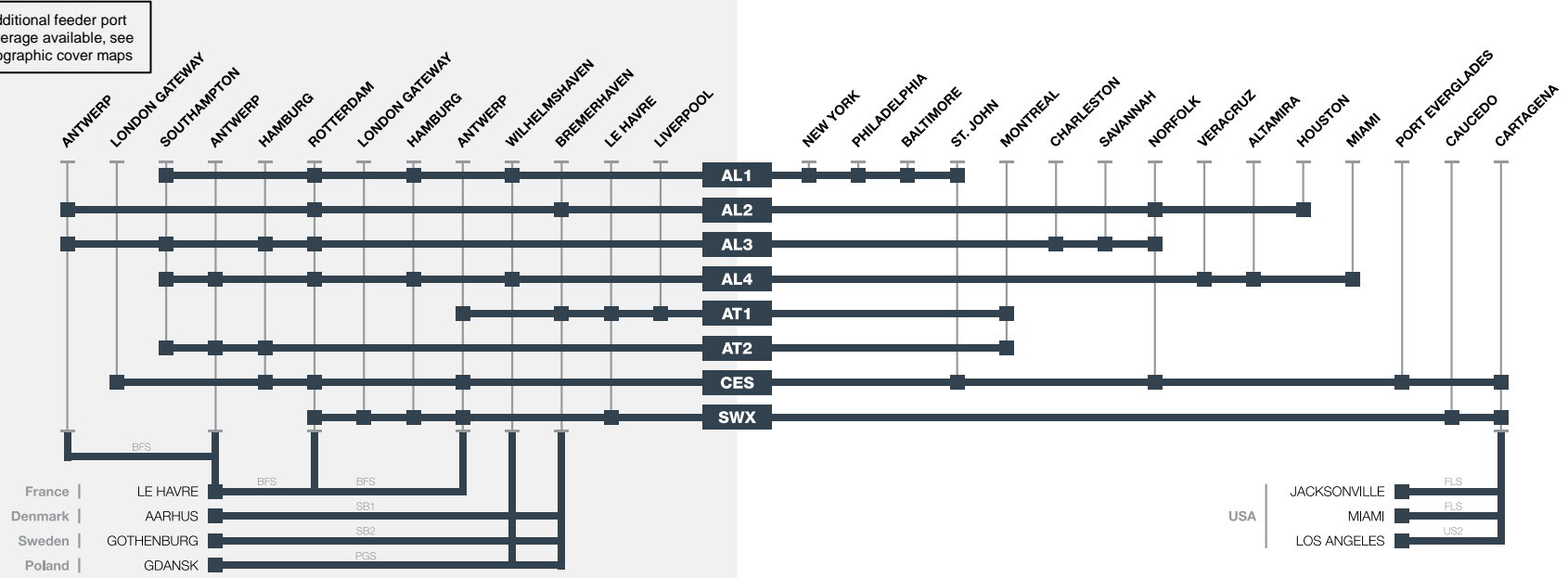

Baltic Shuttle ports can be connected to AL3, AL4, AT2 and CES service via feeder services in Hamburg
 Hapag-Lloyd Mainliner Services outside Gemini Scope: AT1, AT2, CES and SWX

Atlantic

Our North America to North Europe services at a glance

■ Mainliner & Shuttle Services

Additional feeder port coverage available, see geographic cover maps

North America North Europe

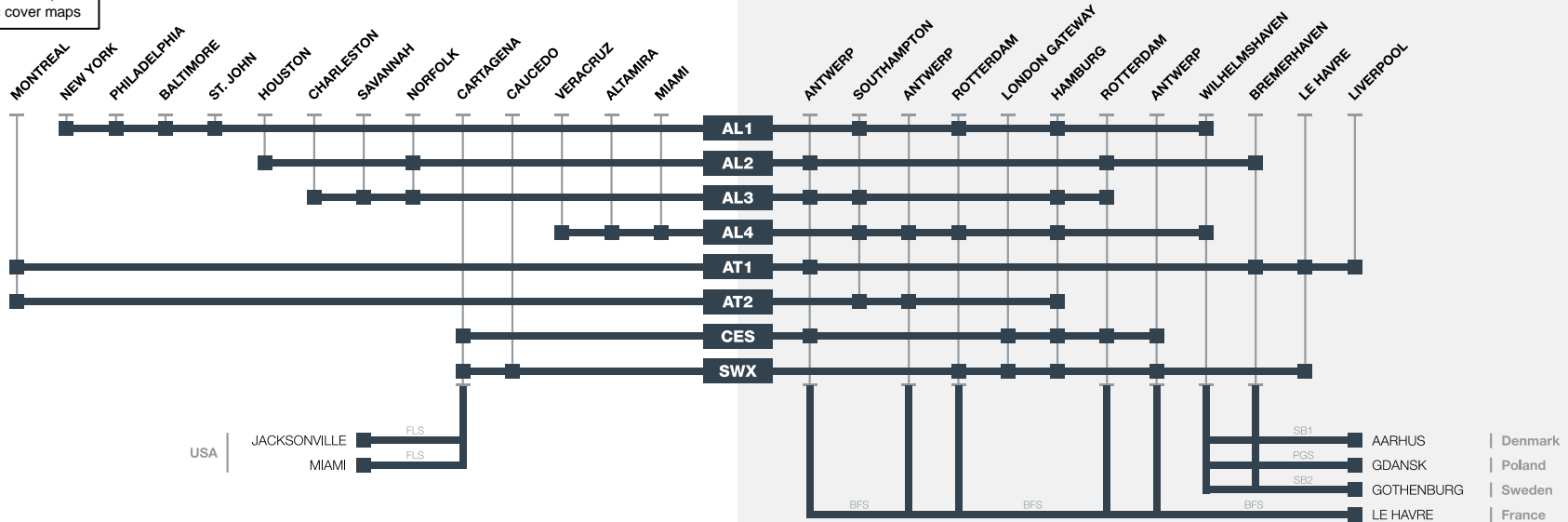

Baltic Shuttle ports can be connected to AL3, AL4, AL1, AT2, CES and SWX service via feeder services in Hamburg
 Hapag-Lloyd Mainliner Services outside Gemini Scope: AT1, AT2, CES and SWX

North Europe - North America

Service Profile AL1

Gemini Cooperation Service



KEY SERVICE VALUE PROPOSITION

- Extended coverage of the US East Coast
- Prime product from Central Europe with two gateway options in Hamburg (DE) and Wilhelmshaven (DE) to New York (US)
- Coverage of Philadelphia (US) and Baltimore (US)

IMPORTANT CONNECTIONS

- Le Havre (FR) connected by dedicated shuttle via Rotterdam with connectivity westbound and eastbound
- Shuttles via Wilhelmshaven (DE) connect to Poland, Sweden and Denmark
- Comprehensive intermodal connections into US Midwest
- Scandinavian markets covered via network of feeders

North Europe - North America

Service Profile AL2

Gemini Cooperation Service

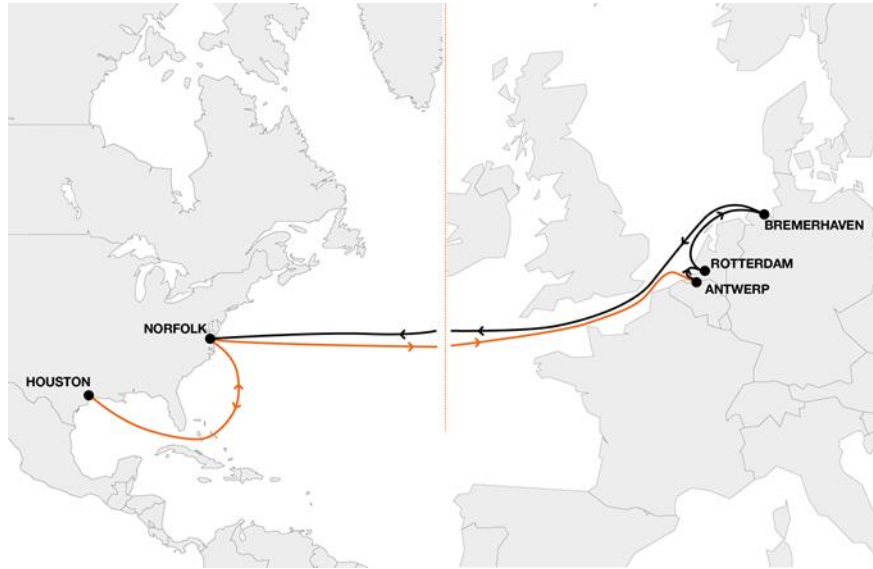

KEY SERVICE VALUE PROPOSITION

- Core service from Benelux and Germany non-stop to Norfolk (US) and Houston (US) as second port westbound
- US Flag Service

IMPORTANT CONNECTIONS

- Le Havre (FR) connected by dedicated shuttle via Rotterdam (NL)
- Shuttles via Bremerhaven (DE) connect to Poland, Sweden and Denmark
- Scandinavian markets covered via network of feeders

North Europe - North America

Service Profile AL3

Gemini Cooperation Service



KEY SERVICE VALUE PROPOSITION

- Concentrated coverage of the South Atlantic market
- Key service for connections from the UK, Germany and Benelux markets to Charleston (US)
- Coverage of the German and Benelux hinterland market eastbound and westbound with calls in both Antwerp (NL) and Rotterdam (NL)

IMPORTANT CONNECTIONS

- Le Havre (FR) connected by dedicated shuttle via Rotterdam (NL)
- Scandinavian markets connected via Hamburg (DE) by a comprehensive feeder network

North Europe - North America

Service Profile AL4

Gemini Cooperation Service

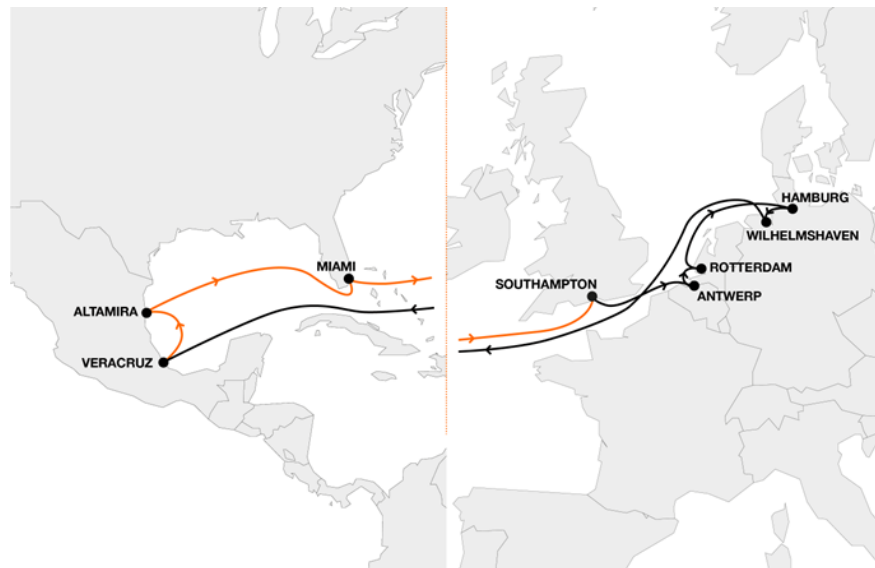

KEY SERVICE VALUE PROPOSITION

- Core Mexico service without stopover in the US on westbound rotation, with key attributes like no U.S. AMS required
- Prime eastbound service from Mexico and Miami (US) to the UK and Benelux markets

IMPORTANT CONNECTIONS

- Le Havre (FR) connected by dedicated shuttle via Rotterdam (NL)
- All Scandinavian markets connected through Wilhelmshaven (DE) by a comprehensive network of feeders

North Europe - North America

Service Profile AT1

Hapag-Lloyd Service



KEY SERVICE VALUE PROPOSITION

- Direct service offering Liverpool and Le Havre in addition to Bremerhaven and Antwerp to Montreal
- Excellent cross-border connection to/from US Midwest

IMPORTANT CONNECTIONS

- Gothenburg (SE), Aarhus (DK) and Gdansk (PL) connected via shuttle services via Bremerhaven (DE)

North Europe - North America

Service Profile AT2

Hapag-Lloyd Service

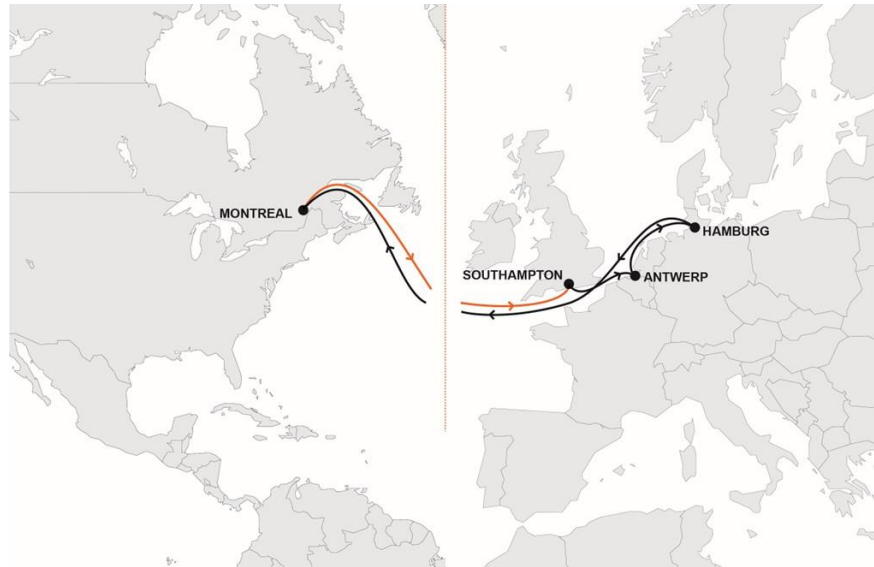

KEY SERVICE VALUE PROPOSITION

- One of the fastest services from North Europe to Montreal
- Excellent cross-border connection to/from US Midwest
- Direct service from Montreal to Southampton

IMPORTANT CONNECTIONS

- Le Havre (FR) connected by dedicated shuttle via Antwerp (BE)
- All Scandinavian and Baltic markets connected via Hamburg (DE) by a comprehensive network of feeders

North Europe - North America

Service Profile CES

Hapag-Lloyd Service

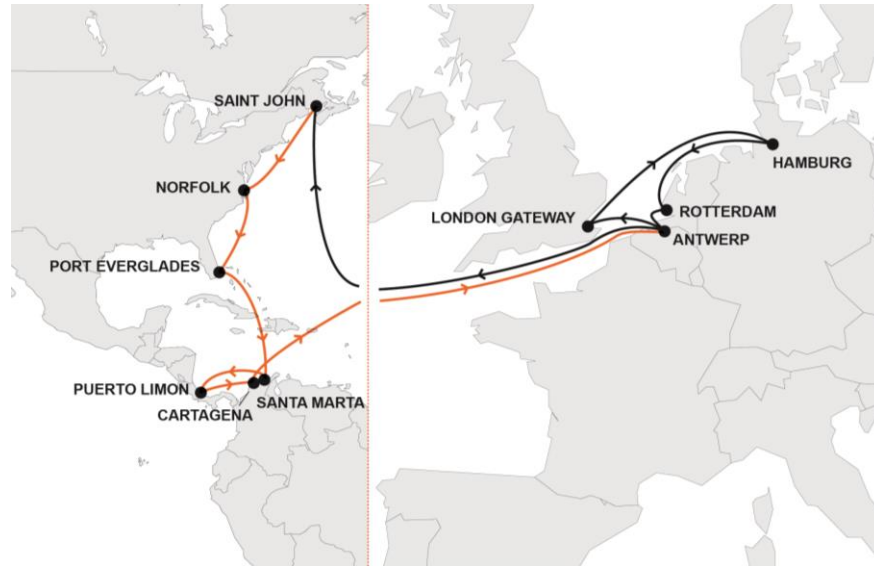

KEY SERVICE VALUE PROPOSITION

- Competitive transit times for the Atlantic and Latin American connections
- Weekly coverage of St. John (NB) paired with the London Gateway & Rotterdam calls and Caribbean connectivity

IMPORTANT CONNECTIONS

- Le Havre (FR) connected by dedicated shuttle via Antwerp (BE) and Rotterdam (NL)
- All Scandinavian and Baltic markets connected via Hamburg (DE) by a comprehensive network of feeders
- Oakland, CA (US) will be connected via Norfolk (US) by mini-land-bridge rail

North Europe - North America

Service Profile SWX

Hapag-Lloyd Service

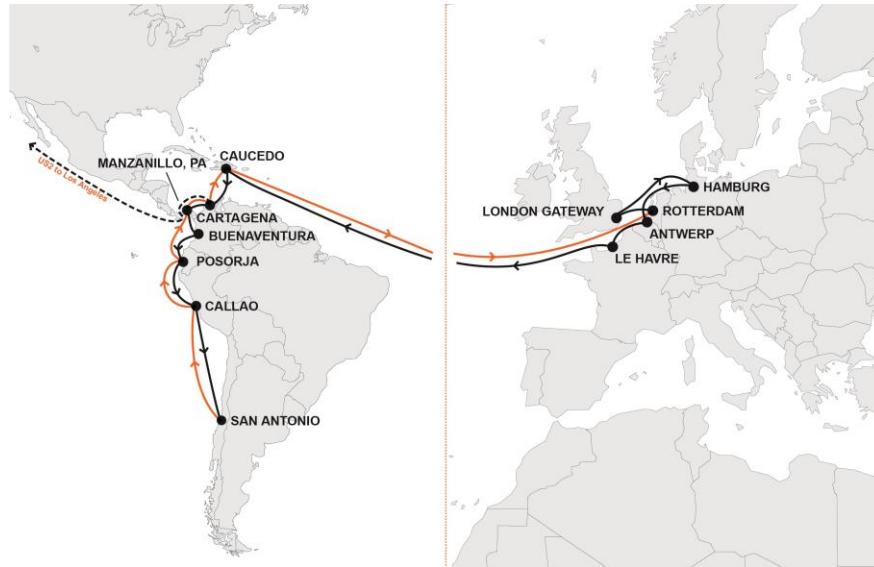
**KEY SERVICE VALUE PROPOSITION**

- Connecting service of the North Europe main ports with a direct transshipment in Cartagena (CO) connecting to the US2 to Los Angeles (US)

IMPORTANT CONNECTIONS

- All Scandinavian and Baltic markets connected via Hamburg (DE) by a comprehensive network of feeders

Atlantic

Port coverage on our North America - South Europe services



Atlantic

Our South Europe to North America services at a glance

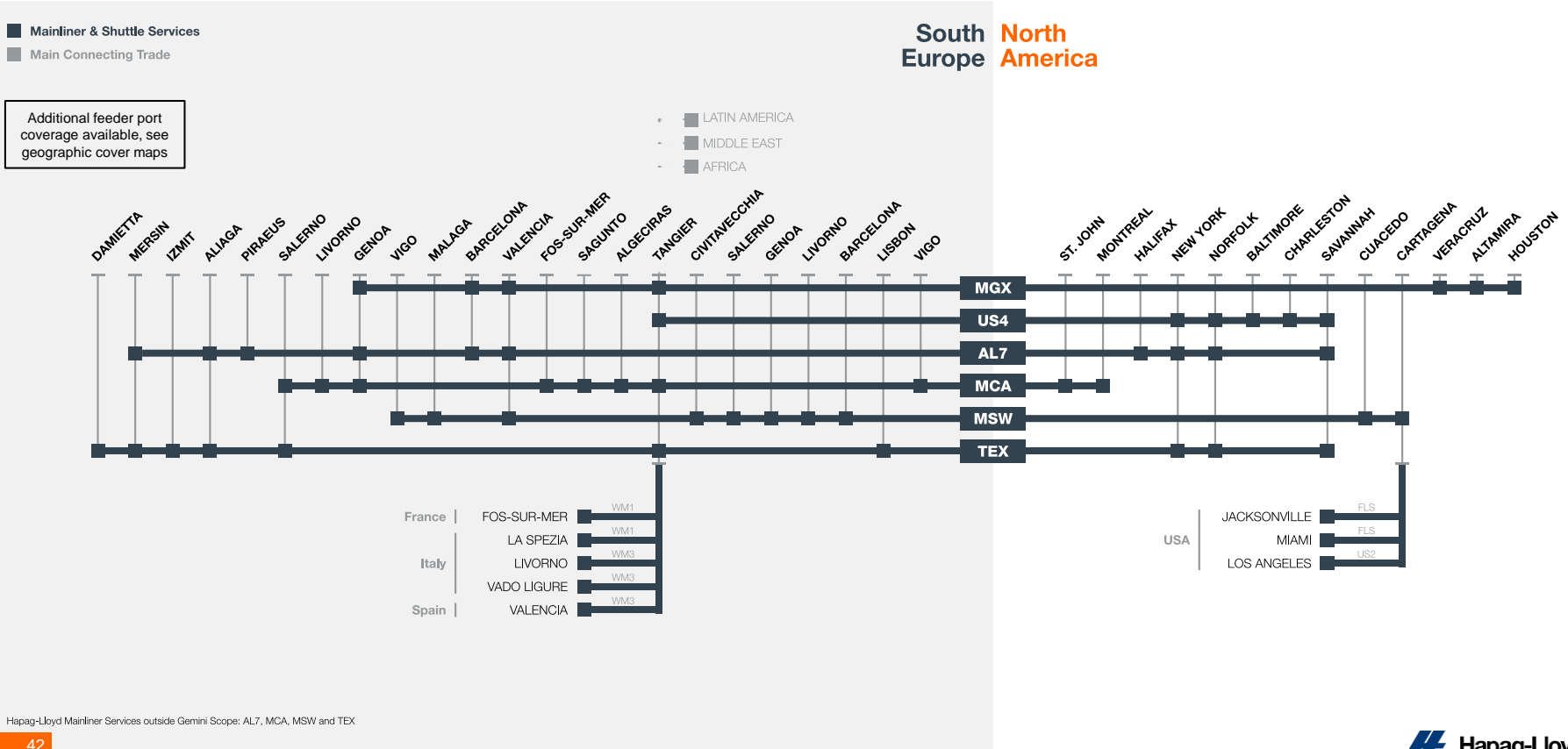

Hapag-Lloyd Mainliner Services outside Gemini Scope: AL7, MCA, MSW and TEX

Atlantic

Our North America to South Europe services at a glance

- Mainliner & Shuttle Services
- Main Connecting Trade

North America South Europe

Additional feeder port coverage available, see geographic cover maps

- LATIN AMERICA
- MIDDLE EAST
- AFRICA

- LATIN AMERICA
- MIDDLE EAST
- AFRICA

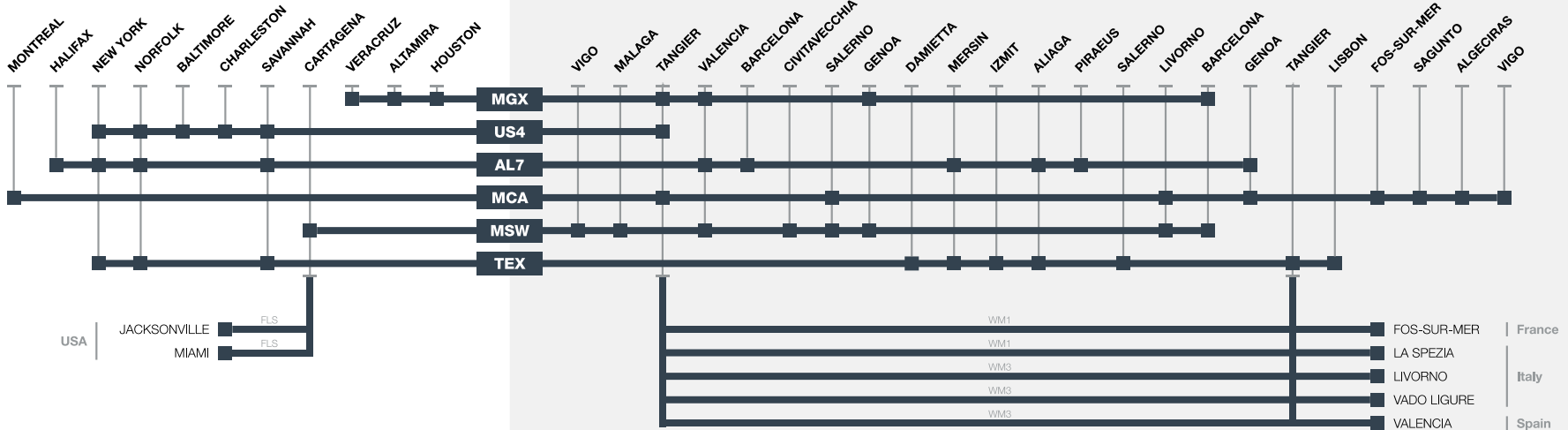

Hapag-Lloyd Mainliner Services outside Gemini Scope: AL7, MCA, MSW and TEX

Mediterranean - North America

Service Profile MGX

Gemini Cooperation Service

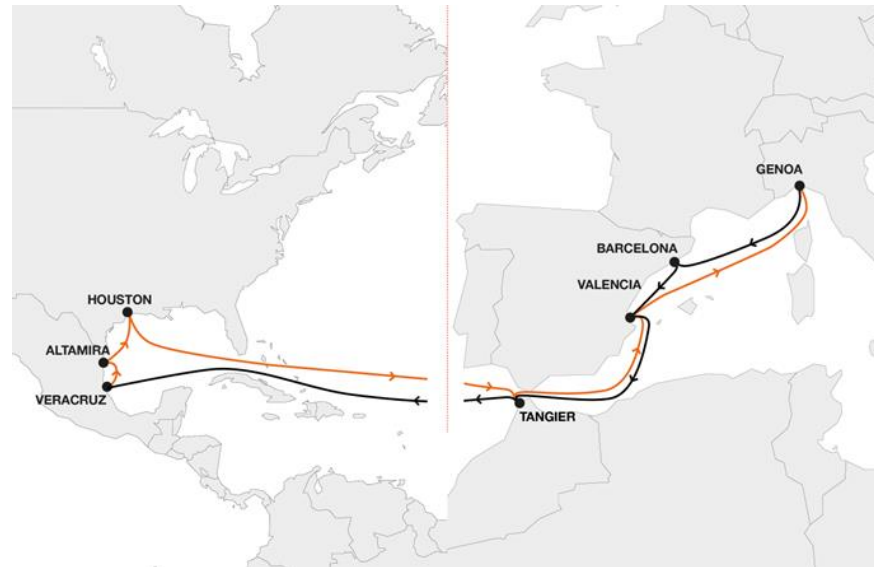

KEY SERVICE VALUE PROPOSITION

- Core West Mediterranean to Mexico service without stopover in the US
- Comprehensive coverage of the Spanish market with non-stop connection from Spain to Mexico
- Eastbound and westbound calls in Valencia (ES) providing excellent connections in both directions

IMPORTANT CONNECTIONS

- Livorno (IT) and Fos-sur-Mer (FR) connected by reliable shuttle via dedicated hub in Tangier (MA)
- Tangier (MA) calls allowing excellent connection to the global network from and to other Mediterranean markets, Africa and the Middle East

Mediterranean - North America

West Med Shuttles + US4

Gemini Cooperation Service

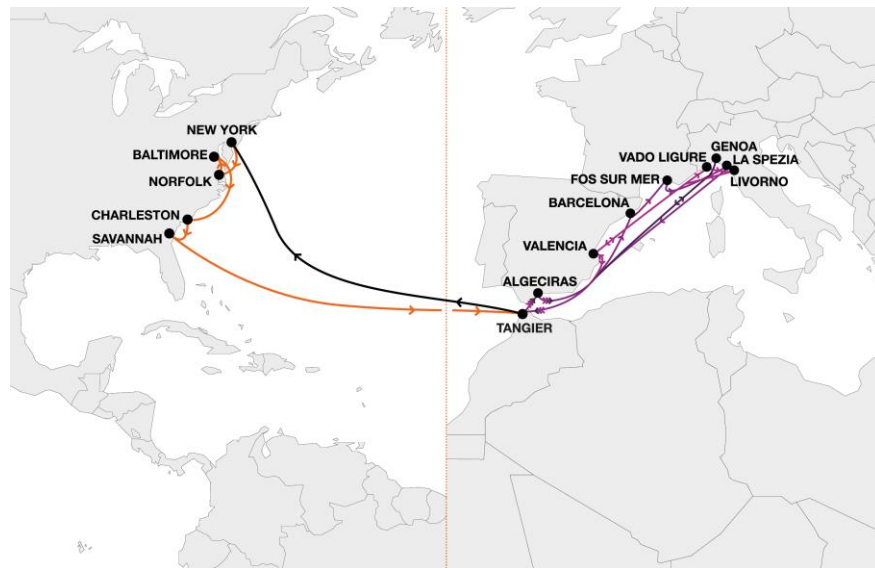

KEY SERVICE VALUE PROPOSITION

- Extensive coverage of West Mediterranean ports to the US East Coast
- Connectivity through shuttle network to US4 service via hub in Tangier (MA)
- New York (US) as first westbound call for fastest transit time
- Addition of Baltimore (US) and Charleston (US) coverage on the US East Coast

IMPORTANT CONNECTIONS

- Tangier (MA) calls allowing excellent connection to the global network from and to Africa and the Middle East

North Europe - North America

Service Profile AL7

Hapag-Lloyd Service

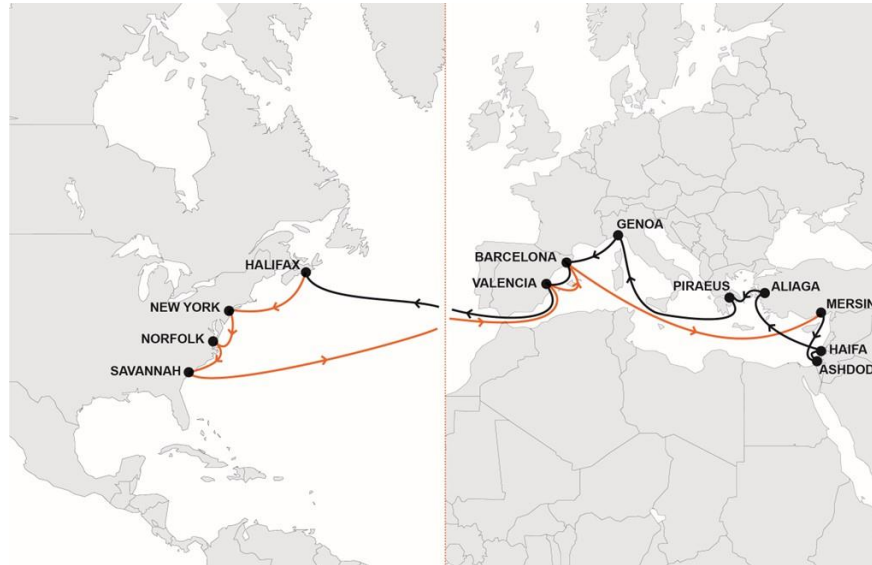

KEY SERVICE VALUE PROPOSITION

- Direct coverage of Israel and Greece with two direct Turkish ports
- Additional Eastern Mediterranean and Black Sea ports linked via own feeder network

IMPORTANT CONNECTIONS

- Shuttles from Valencia (ES) connecting imports via Tangier (MA) to our global network

North Europe - North America

Service Profile MCA

Hapag-Lloyd Service

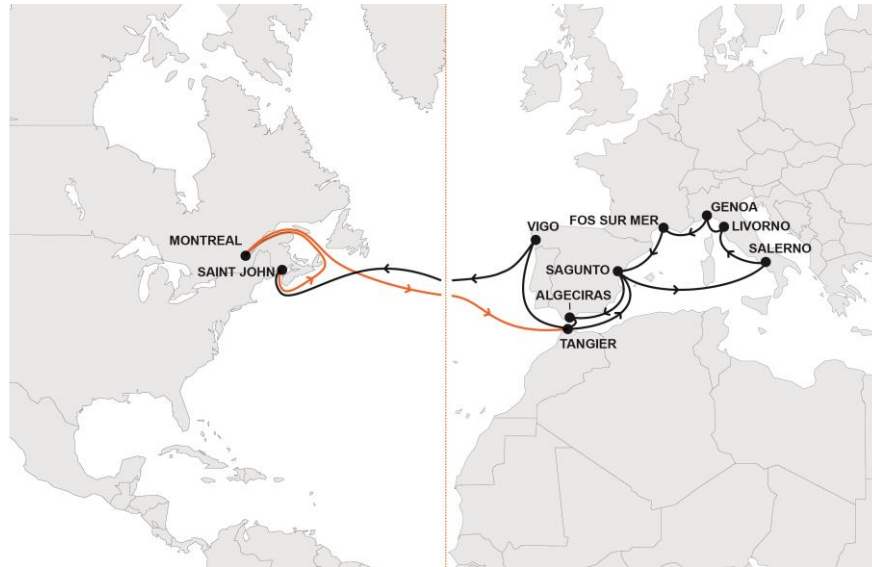

KEY SERVICE VALUE PROPOSITION

- Service offering excellent transit times to/from Montreal
- Excellent cross-border connection to/from US Midwest, for imports to US Midwest also via St. John
- Very comprehensive direct port coverage in the Med
- Hub in Tangier allows for cross-trade business between Montreal and Africa,
- South America Eastcoast and Middle East/India

IMPORTANT CONNECTIONS

- Shuttles via Tangier (MA) to connect to our global network

North Europe - North America

Service Profile TEX

Hapag-Lloyd Service

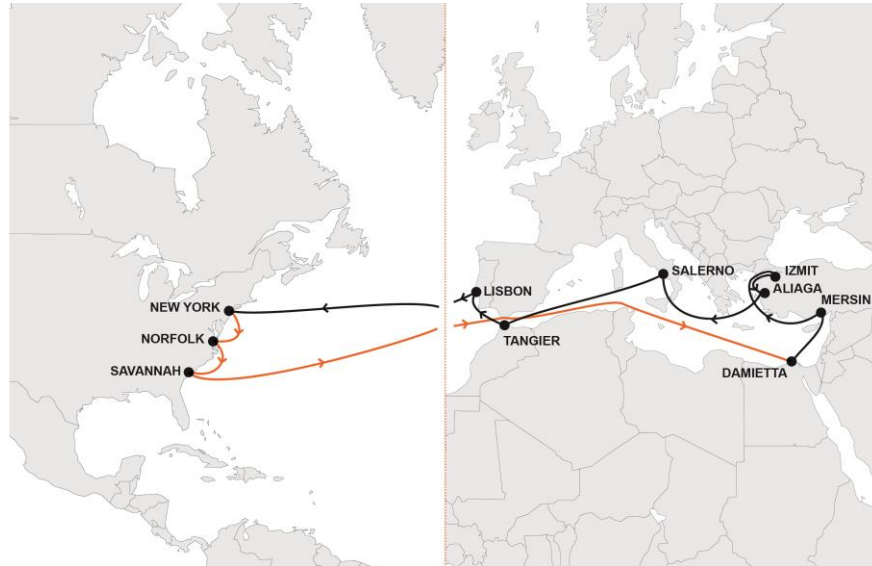
**KEY SERVICE VALUE PROPOSITION**

- Fast and direct connection between major Turkish and US East Coast ports
- Salerno connected directly to US East Coast
- Connecting Turkey via the hub in Tangier to our global network

IMPORTANT CONNECTIONS

- Shuttles via Tangier (MA) to connect to Valencia (ES), Livorno (IT), La Spezia (IT) and Fos sur mer (FR)

North Europe - North America

Service Profile MSW

Hapag-Lloyd Service

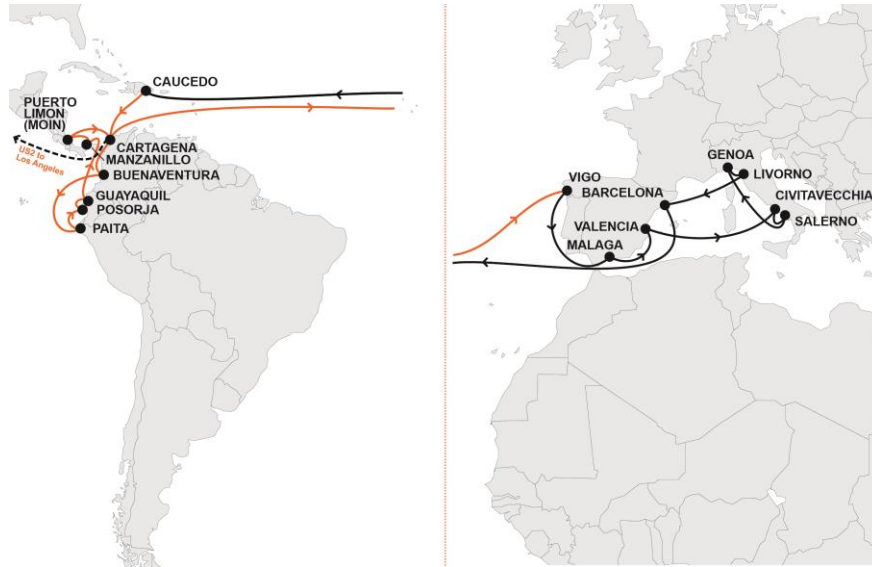
**KEY SERVICE VALUE PROPOSITION**

- Connecting a wide range of Mediterranean ports via transshipment to the US West Coast

IMPORTANT CONNECTIONS

- Link to US West Coast, Miami (US) and Jacksonville (US) via Cartagena (CO)

Agenda

- | | | |
|-----------|--|-----------|
| A. | Hapag-Lloyd East-West Service Network at a Glance | 2 |
| B. | Trade Overview Asia - Europe | 7 |
| C. | Trade Overview Atlantic | 28 |
| D. | Trade Overview Transpacific | 52 |
| E. | Trade Overview Middle East | 73 |
| F. | Overview Shuttle Network and Intra Regional Trades | 87 |

Transpacific

Highlights of our Transpacific service

- Comprehensive Transpacific product with unrivalled reliability
- Delivering robust, on-time and weekly service schedules to our customers
- The new network will provide connections between all key Asia and North American ports and gateways with further inland connections to all key rail ramps and doors
- Extensive coverage of Southeast Asia and Japan through our shuttle network via hubs
- Seamless connection through our innovative Hub & Spoke system

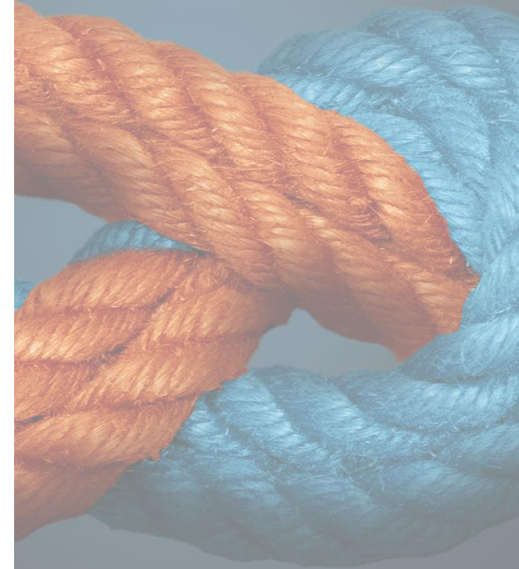

Transpacific

Our Transpacific service in numbers

KEY FACTS

12

Services

121

Vessels

7

Ø Calls per service

10.5 TTEU

Ø Vessel size

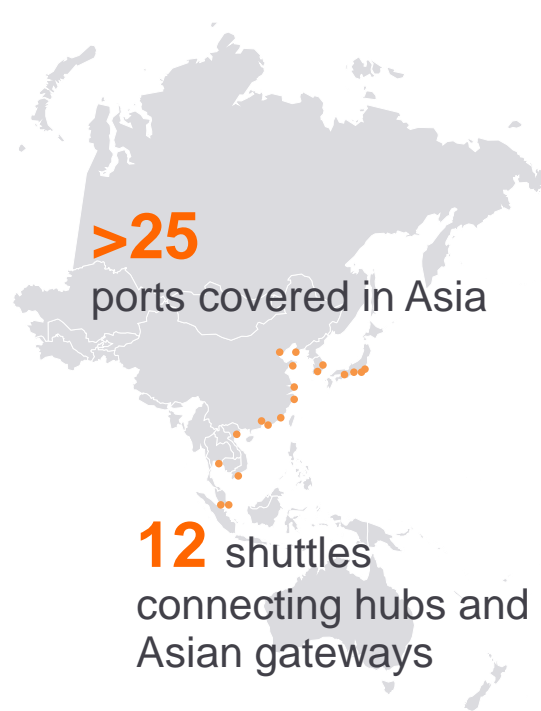

Transpacific

Port coverage on our Transpacific services



Transpacific

Our Asia to US West Coast services at a glance

■ Mainliner & Shuttle Services

Asia US West Coast

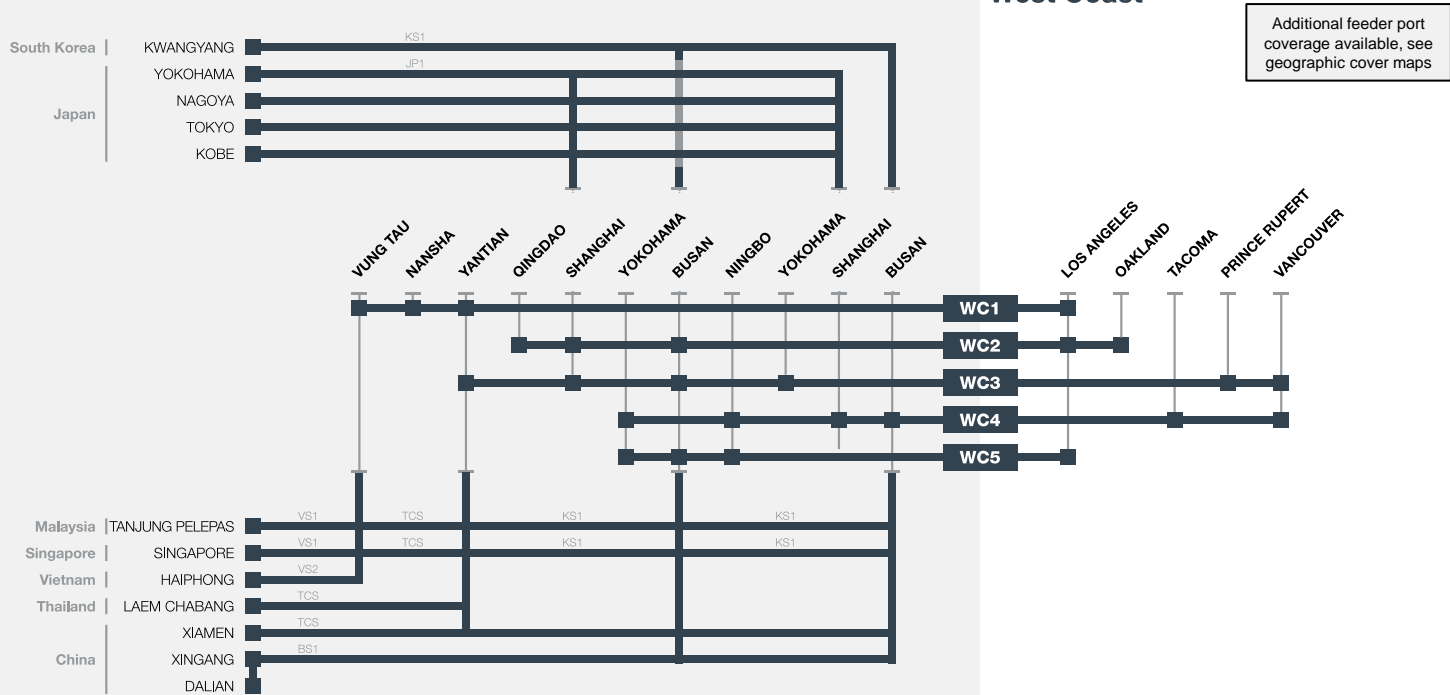

All displayed Services are part of the Gemini Cooperation

Transpacific

Our US West Coast to Asia services at a glance

■ Mainliner & Shuttle Services

Additional feeder port coverage available, see geographic cover maps

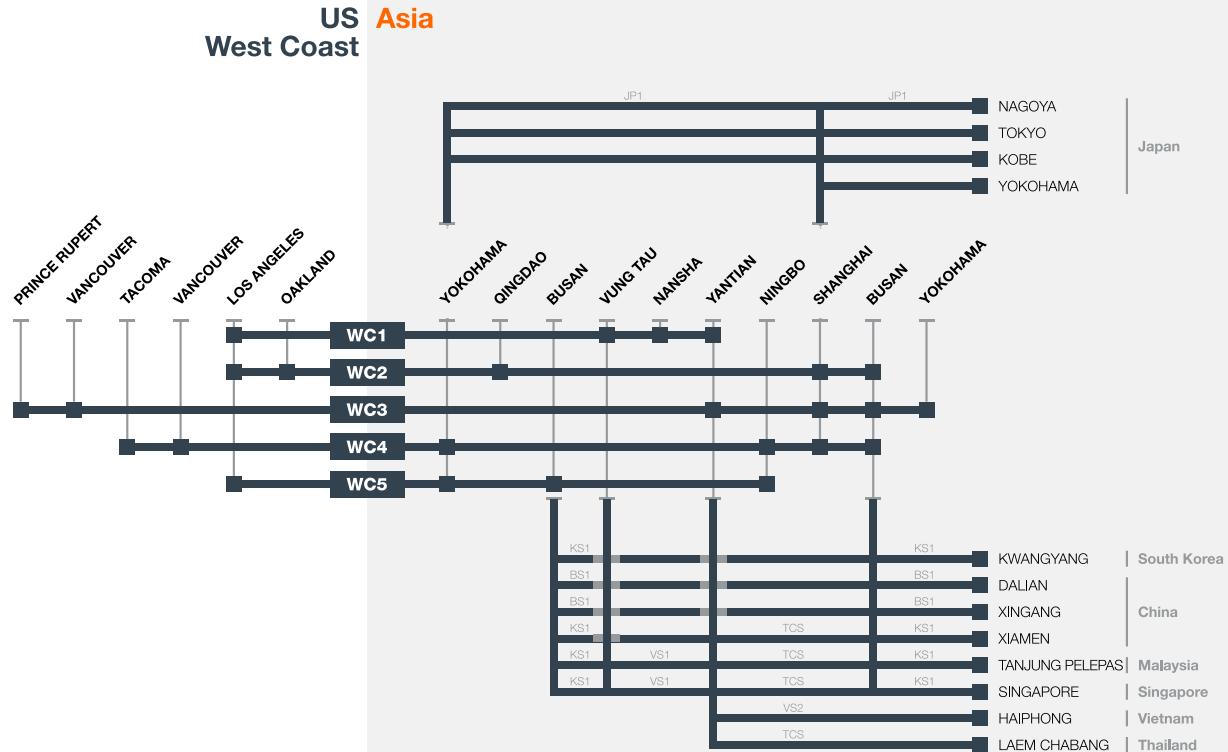

All displayed Services are part of the Gemini Cooperation

Asia - US West Coast

Service Profile WC1

Gemini Cooperation Service



KEY SERVICE VALUE PROPOSITION

- Key service to connect Southeast Asia to the US West Coast
- Direct connection from Yantian (CN) to Los Angeles (US)
- Direct connection from Los Angeles (US) to Vung Tau (VN)

IMPORTANT CONNECTIONS

- Shuttles via Yantian (CN) and Vung Tau (VN) serve Southeast Asia markets

Asia - US West Coast

Service Profile WC2

Gemini Cooperation Service



KEY SERVICE VALUE PROPOSITION

- Key service to connect Central China and South Korea to the US West Coast
- Direct connection from Busan (KR) to Los Angeles (US)
- Direct connection from Oakland (US) to Qingdao (CN)

IMPORTANT CONNECTIONS

- Shuttles from Shanghai (CN) serve Japan
- Shuttles from Busan serve the markets of the Bohai Sea

Asia - Canada West Coast

Service Profile WC3

Gemini Cooperation Service



KEY SERVICE VALUE PROPOSITION

- Key service to connect China, South Korea and Japan to the Canada West Coast
- Canada only service to Vancouver (CA) and direct connection to Prince Rupert (CA)

IMPORTANT CONNECTIONS

- Shuttles from Yantian (CN) connects to Laem Chabang (TH), Haiphong (VN) and Vung Tau (VN)
- Inland network connects to all key rail ramps and doors in Canada and the US

Asia - Canada & US West Coast

Service Profile WC4

Gemini Cooperation Service



KEY SERVICE VALUE PROPOSITION

- Key service to connect Central China, South Korea and Japan to the Canada West Coast and US West Coast
- Direct connection from Busan (KR) to Tacoma (US)
- Direct connection from Vancouver (CA) to Yokohama (JP)

IMPORTANT CONNECTIONS

- Shuttles from Busan (KR) connect to Qingdao (CN), Dalian (CN), and Xingang (CN)
- Further Shuttle via Busan (KR) allows for connection to the Southeast Asian Gateways
- Inland network connects to all key rail ramps and doors in Canada and the US

Asia - US West Coast

Service Profile WC5

Gemini Cooperation Service

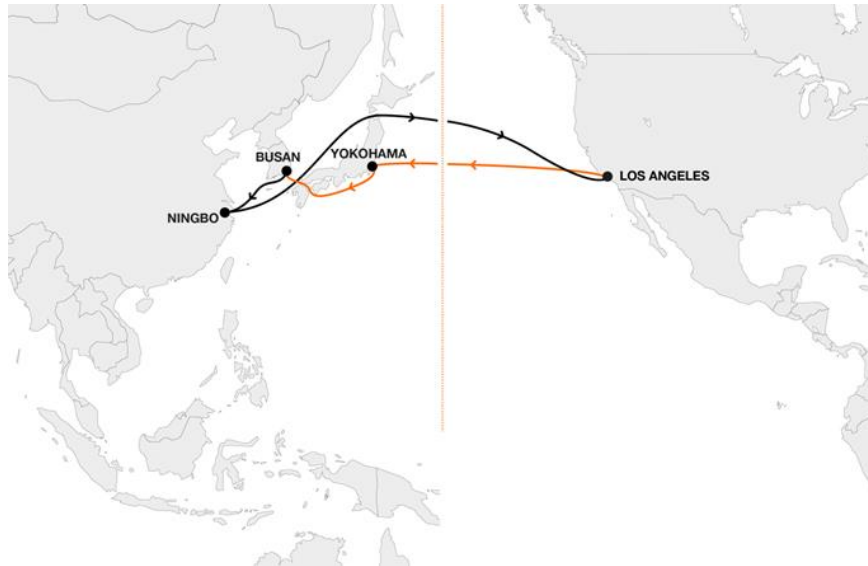

KEY SERVICE VALUE PROPOSITION

- Key service to connect Central China, South Korea and Japan to the US West Coast
- Direct connection from Ningbo (CN) to Los Angeles (US)
- Direct connection from Los Angeles (US) to Yokohama (JP)
- US Flag Service

IMPORTANT CONNECTIONS

- Shuttle from Busan (KR) serve the markets of the Bohai Sea
- Shuttle from Yokohama (JP) covers additional Japanese ports

Transpacific

Our Asia to US East Coast services at a glance

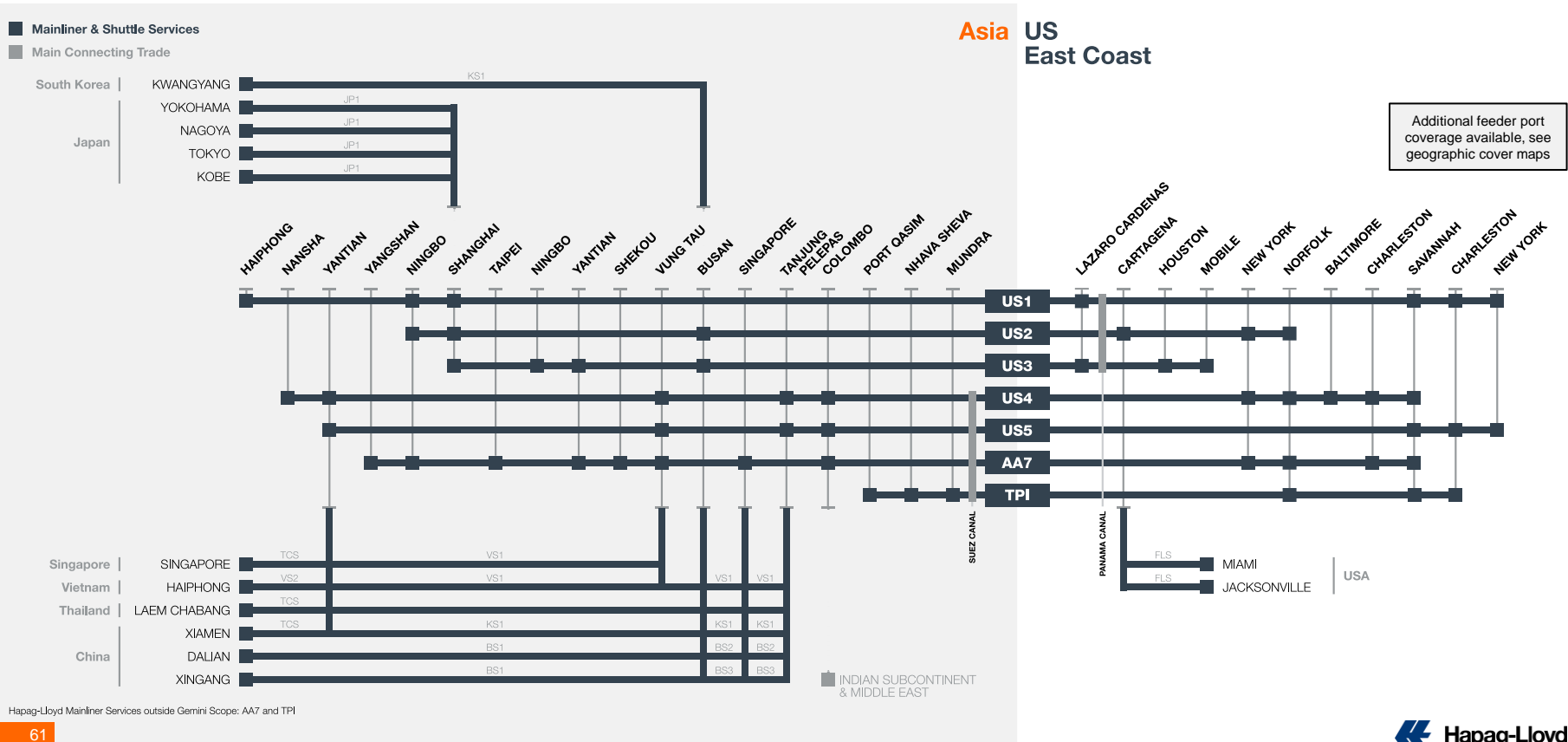

Hapag-Lloyd Mainliner Services outside Gemini Scope: AA7 and TPI

Transpacific

Our US East Coast to Asia services at a glance

- Mainliner & Shuttle Services
- Main Connecting Trade

US East Coast Asia

Additional feeder port coverage available, see geographic cover maps

- LATIN AMERICA
- ATLANTIC

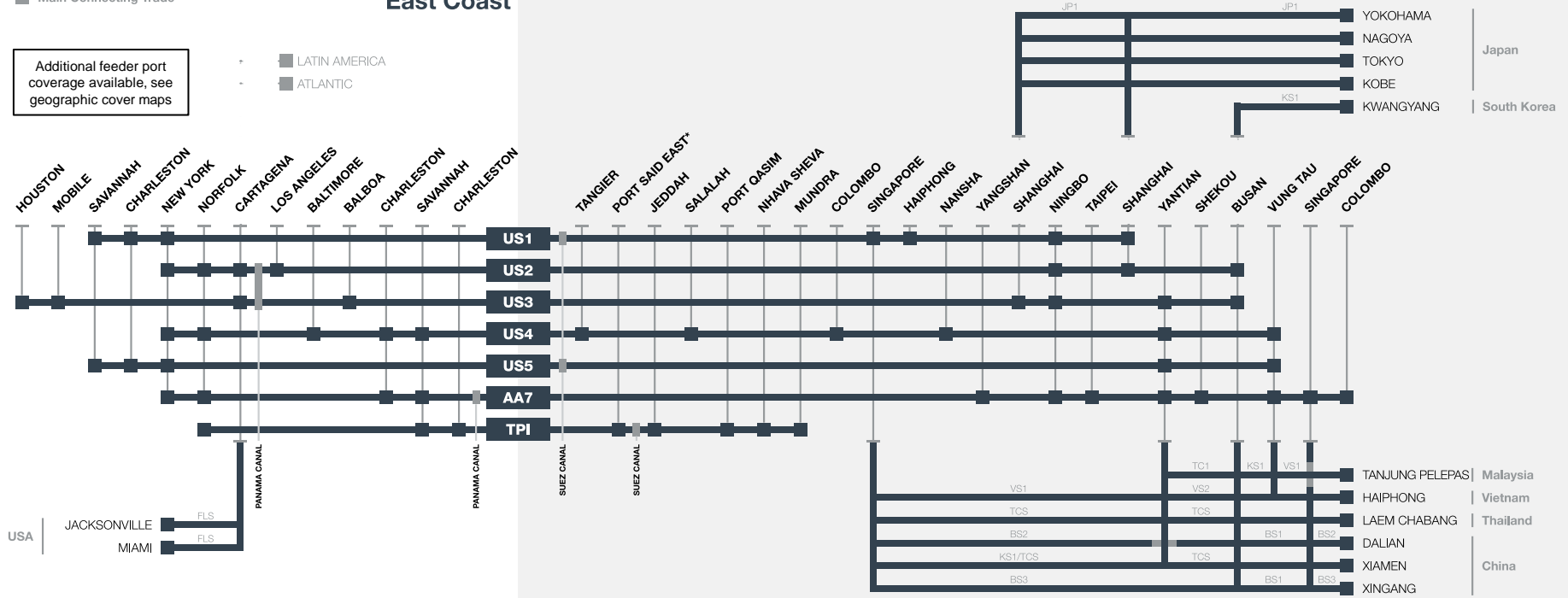

Hapag-Lloyd Mainliner Services outside Gemini Scope: AA7 and TPI

Asia - US East Coast

Service Profile US1

Gemini Cooperation Service

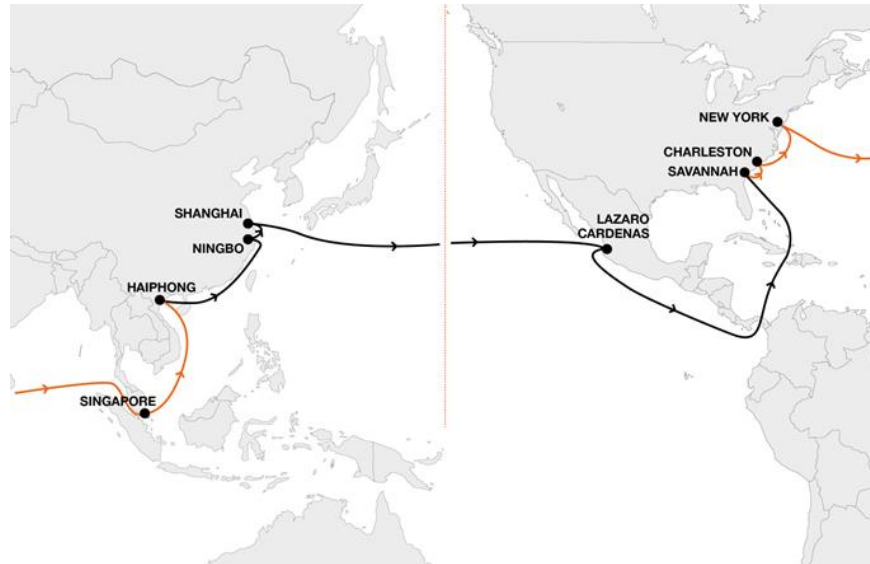

KEY SERVICE VALUE PROPOSITION

- Key service to connect Central China and Southeast Asia to the US East Coast via the Panama Canal
- Direct connection from Shanghai (CN) to Lazaro Cardenas (MX)

IMPORTANT CONNECTIONS

- Shuttles from Shanghai (CN) connect to Japan
- Cross-border rail network accesses to Dallas (US) via Lazaro Cardenas (MX)
- Southeast Asia coverage via Singapore (SG)

Asia - US East Coast

Service Profile US2

Gemini Cooperation Service

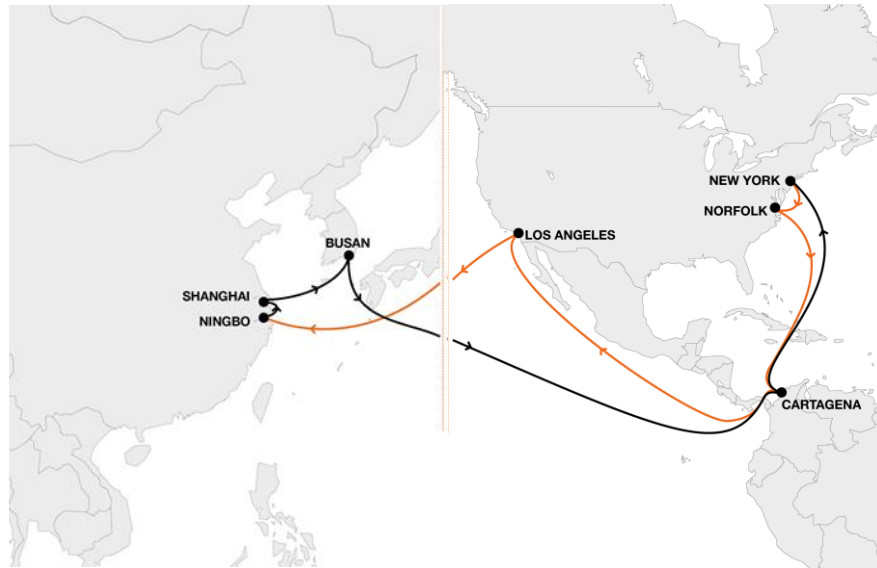
**KEY SERVICE VALUE PROPOSITION**

- Key service to connect Central China, South Korea and Japan to the US East Coast
- Direct connection from Los Angeles (US) to Ningbo (CN)

IMPORTANT CONNECTIONS

- Shuttles from Shanghai (CN) connect to Japan
- Shuttles from Busan (KR) serve the markets of the Bohai Sea
- Direct connection to Cartagena (CO) serves as a link to Latin American markets and Florida (US)

Asia - US Gulf Coast

Service Profile US3

Gemini Cooperation Service

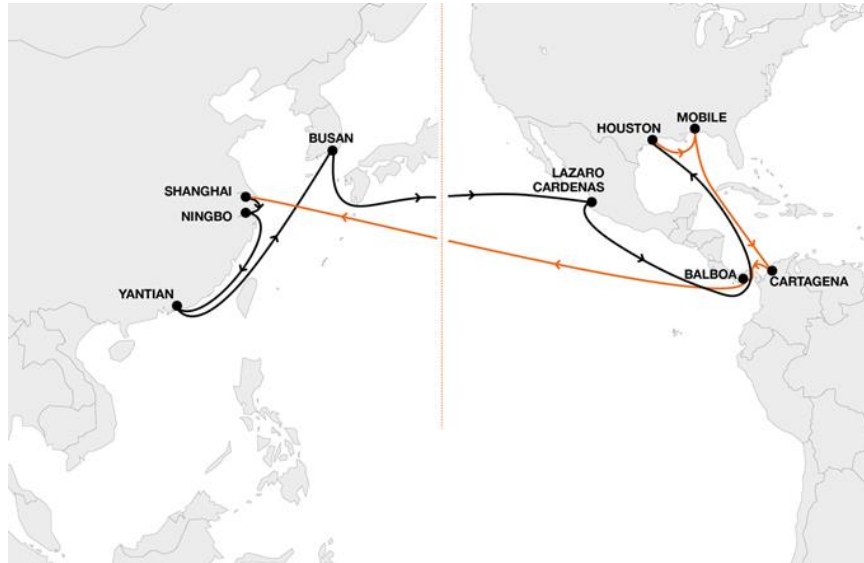

KEY SERVICE VALUE PROPOSITION

- Key service to connect Central China, South Korea and Japan to the US Gulf Coast
- Direct connection from Busan (KR) to Lazaro Cardenas (MX)

IMPORTANT CONNECTIONS

- Shuttles from Shanghai (CN) connect Japan to the US Gulf Coast
- Cross-border rail network accesses to Dallas (US) via Lazaro Cardenas (MX)
- Connection to Cartagena serves as a link to Latin American markets and Florida (US)

Asia - US East Coast

Service Profile US4

Gemini Cooperation Service



KEY SERVICE VALUE PROPOSITION

- Key service to connect the US East Coast with Asia via the Suez Canal with stopovers in Tangier (MA) and Salalah (OM)
- Coverage of all US East coast ports

IMPORTANT CONNECTIONS

- Shuttles via Tanjung Pelepas (MY) connect Southeast Asia to the US East Coast
- Shuttles via Salalah (OM) connect the Middle East

Asia - US East Coast

Service Profile US5

Gemini Cooperation Service

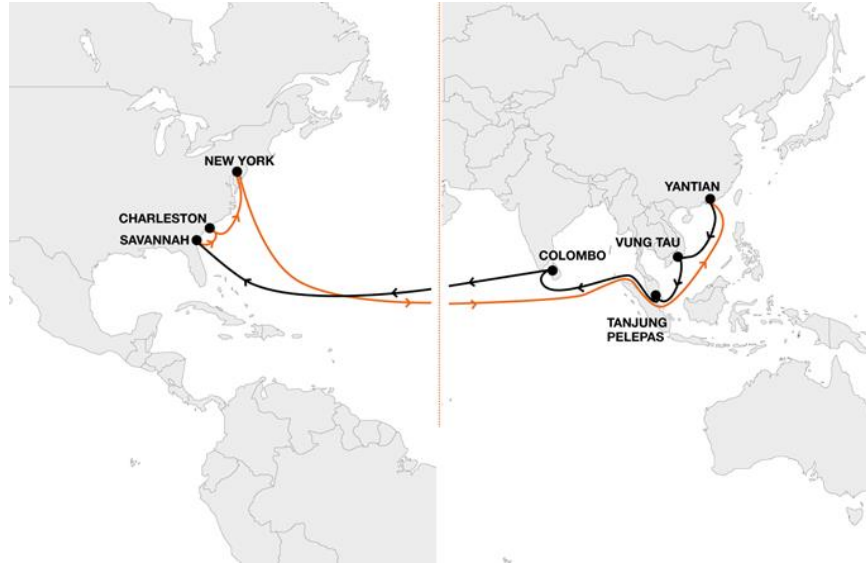

KEY SERVICE VALUE PROPOSITION

- Key service to connect Southeast Asia with the US East Coast

IMPORTANT CONNECTIONS

- Shuttles via Tanjung Pelepas (MY) connect Southeast Asia to the South Atlantic ports

Asia - US East Coast

Service Profile AA7

Hapag-Lloyd Service

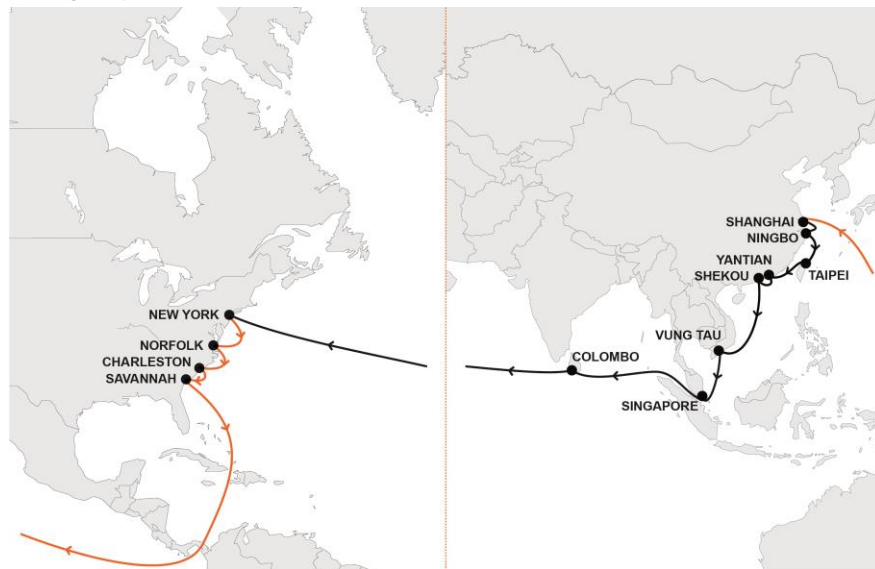
**KEY SERVICE VALUE PROPOSITION**

- More connections from East Asia and Southeast Asia
- Enhanced rotation with two additional ports: Shanghai and Colombo
- Calling APM terminal in New York/New Jersey with infrastructure connectivity, modern IT systems and largest Reefer capacity in the region
- On dock rail services

IMPORTANT CONNECTIONS

- Shuttles via Shanghai (CN) for Korean and Japanese and via Singapore (SG) for Southeast Asian, South China and Bohai sea cargo
- Connection via Colombo (LK) into the Indian subcontinent
- Comprehensive intermodal connections into the US Midwest

Indian Subcontinent - US East Coast

Service Profile TPI

Hapag-Lloyd Service

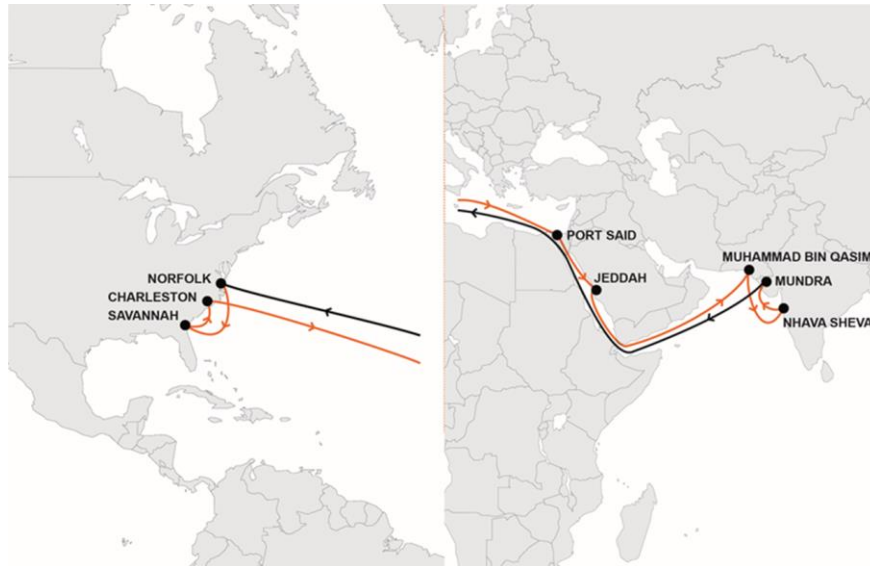

KEY SERVICE VALUE PROPOSITION

- TPI (Indamex) is THE premium service in North/Central India, Pakistan and US East Coast Market. With the TPI we offer outstanding service in ISC-US East coast market
- The TPI service has been augmented by the TPI extra loaders to help our customers to better connect to the US and put some relief on the continuous high demand.

IMPORTANT CONNECTIONS

- Comprehensive intermodal connections into the US Midwest

Agenda

- | | | |
|-----------|--|-----------|
| A. | Hapag-Lloyd East-West Service Network at a Glance | 2 |
| B. | Trade Overview Asia - Europe | 7 |
| C. | Trade Overview Atlantic | 28 |
| D. | Trade Overview Transpacific | 52 |
| E. | Trade Overview Middle East | 73 |
| F. | Overview Shuttle Network and Intra Regional Trades | 87 |

Middle East

Highlights of our Middle East service

- Comprehensive Middle East product with unrivalled reliability
- Delivering robust, on-time and weekly service schedules to our customers
- Broad coverage of all key markets in Middle East, North and South Europe through a dedicated shuttle network, seamlessly connected in selected own / and or controlled hubs
- Multiple options with enhanced connectivity to key trades like Africa, Atlantic, Far East, Latin America and Transpacific

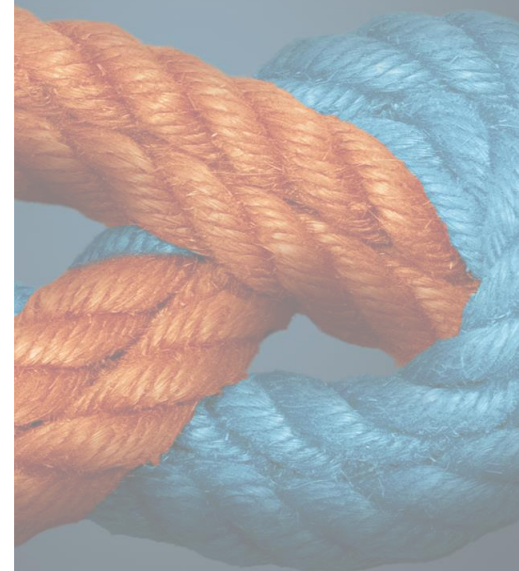

Middle East

Our Middle East service in numbers

KEY FACTS

4

Services

31

Vessels

10

Ø Calls per service

14.0 TTEU

Ø Vessel size

>38

ports covered in Europe

>18

ports covered in Middle East

17 shuttles
connecting
hubs and
European
gateways6 shuttles
connecting hubs
and Middle Eastern
gatewaysGo to shuttle
network

Middle East

Port coverage on our Middle East – North Europe services



Middle East

Our Middle East to North Europe services at a glance

■ Mainliner & Shuttle Services

Additional feeder port coverage available, see geographic cover maps

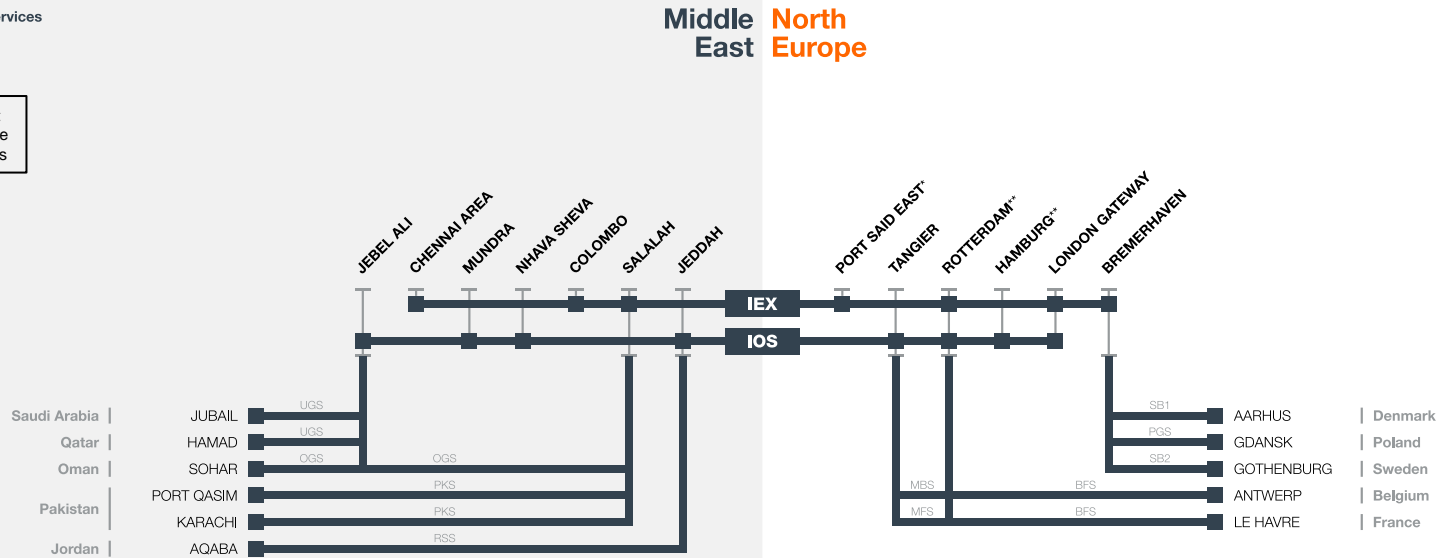

All displayed Services are part of the Gemini Cooperation
 * Certain Port Said East EB Calls will be shifted to Damietta during 2025
 ** Transpacific & Latin America connected via NC

Middle East

Our North Europe to Middle East services at a glance

■ Mainliner & Shuttle Services

Additional feeder port coverage available, see geographic cover maps

North Europe Middle East

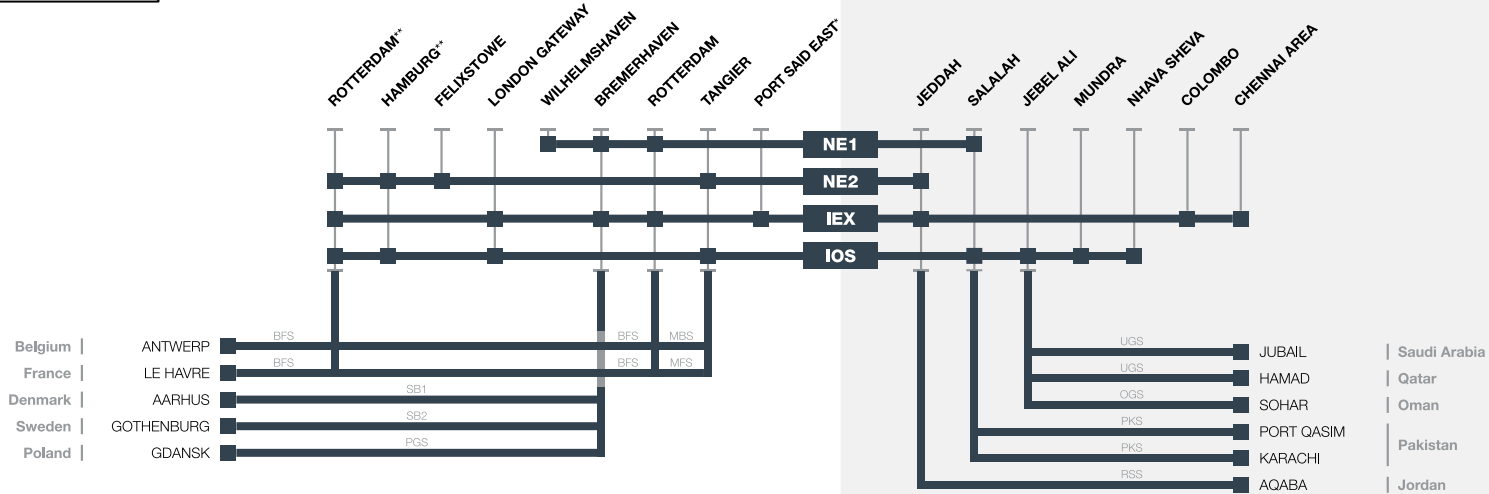

All displayed Services are part of the Gemini Cooperation
 * Certain Port Said East EB Calls will be shifted to Damietta during 2025
 ** Transpacific & Latin America connected via NC HUBS

Middle East - North Europe

Service Profile IEX

Gemini Cooperation Service

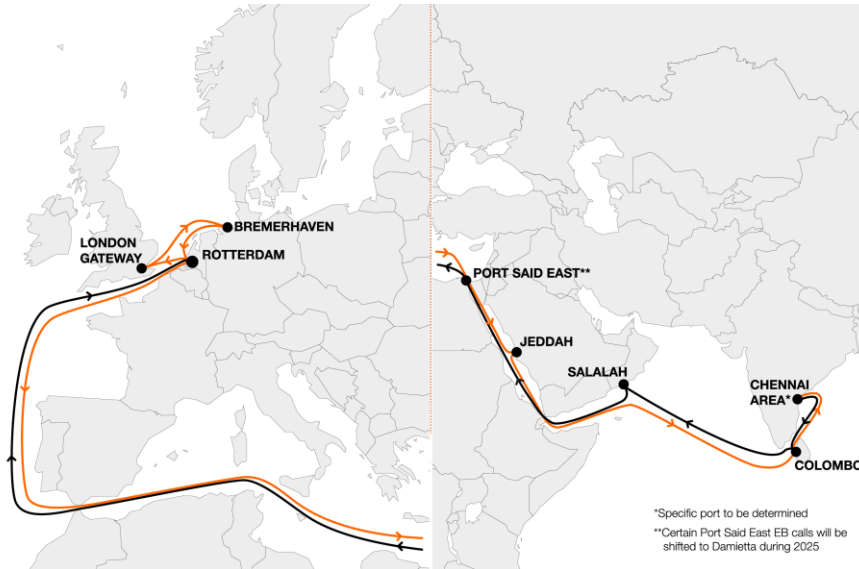

KEY SERVICE VALUE PROPOSITION

- Key service for connections from the Indian Subcontinent to North Europe through the Middle East via the Suez Canal
- Connection especially relevant for sensitive and high value cargo of those markets, e.g. reefer, OOG and break-bulk

IMPORTANT CONNECTIONS

- Shuttles via Rotterdam (NL) connect Le Havre (FR) and Antwerp (BE)
- Shuttles from and to the Indian market enable fast and efficient transit to Türkiye, Levant and Greece plus Black Sea markets covered via additional feeders from Port Said East (EG)
- Connecting the Baltic and Scandinavian markets via Bremerhaven (DE)

Middle East - North Europe

Service Profile IOS

Gemini Cooperation Service

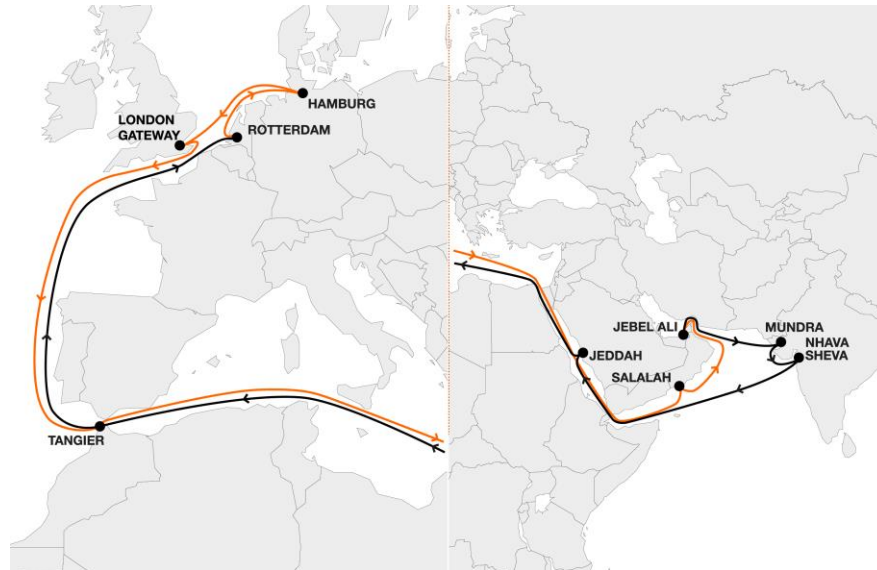

KEY SERVICE VALUE PROPOSITION

- Key service between North Europe, the Indian Subcontinent, Red Sea and Arabian Gulf via the Suez Canal
- Serving the markets of Africa, US East Coast and Latin America through a direct connection to Tanger (MA)
- Additional coverage of Jebel Ali (AE), Salah (OM), Mundra (IN) and Nhava Sheva (IN) next to IMX

IMPORTANT CONNECTIONS

- Shuttles from Tanger (MA) as well as Rotterdam (NL) connect Le Havre (FR) and Antwerp (BL)
- The Baltic and Scandinavian markets are connected via Hamburg (DE) through additional feeders
- Several connection options from the Arabian Gulf, Indian Subcontinent and Red Sea, e.g. into Pakistan through shuttles via Salah (OM)

Middle East

Port coverage on our Middle East – South Europe services

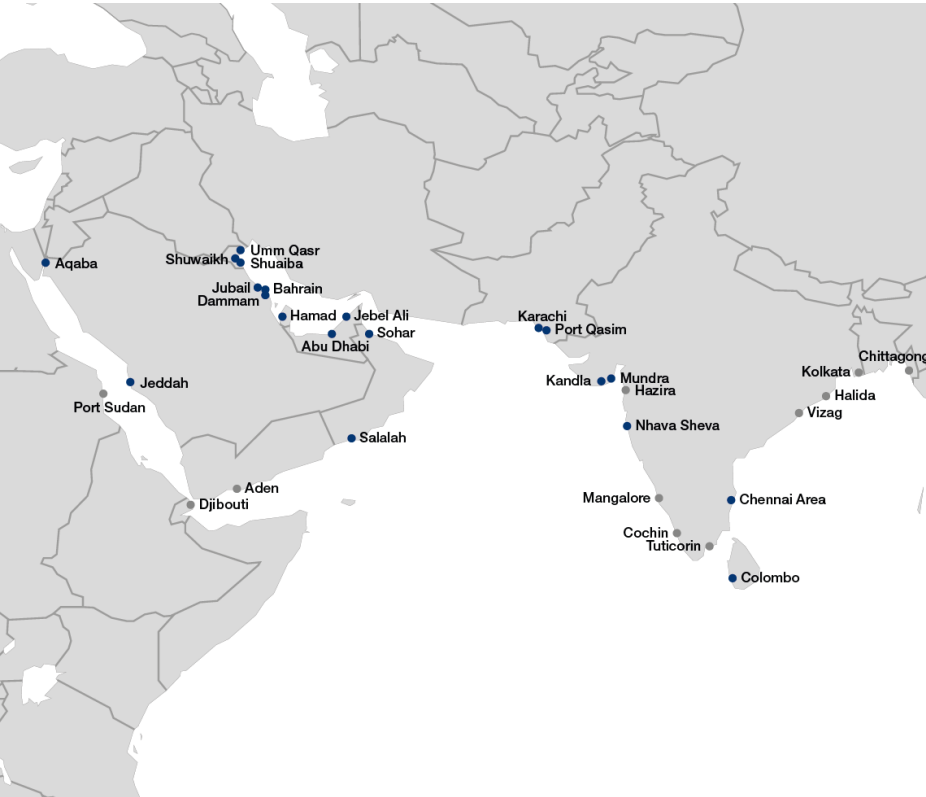

Middle East

Our Middle East to South Europe services at a glance

■ Mainliner & Shuttle Services

Middle East South Europe

Additional feeder port coverage available, see geographic cover maps

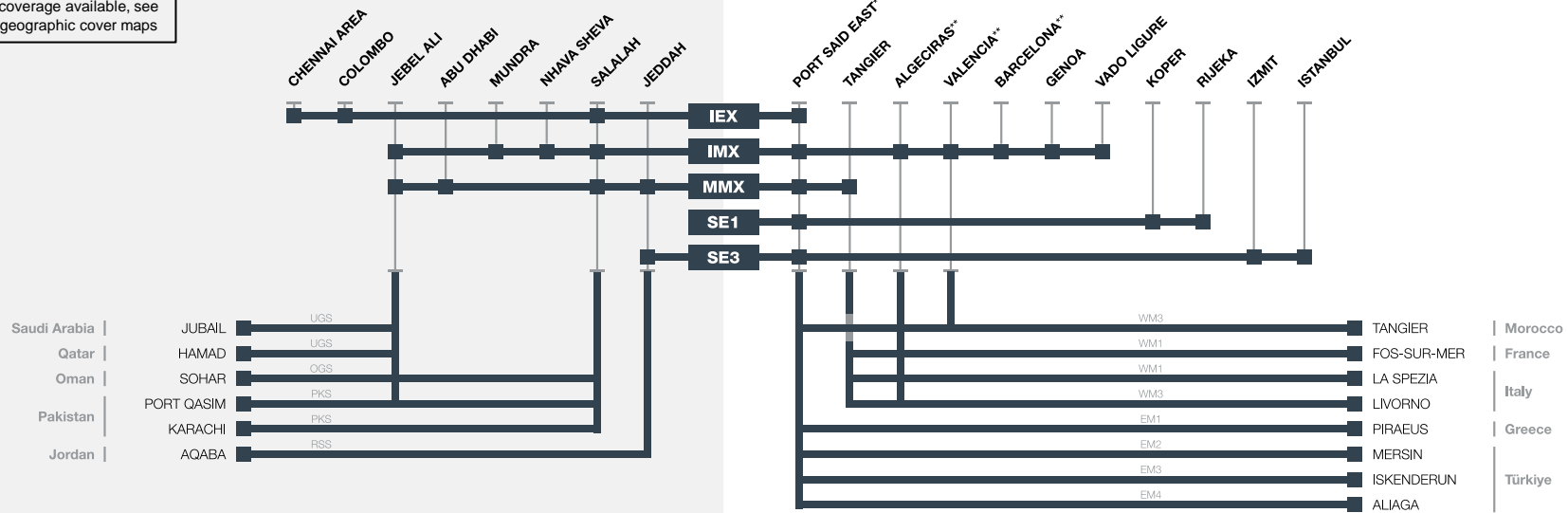

All displayed Services are part of the Gemini Cooperation
 * Certain Port Said East EB Calls will be shifted to Damietta during 2025
 **Transpacific & Latin America connected via West MED HUB

Middle East

Our South Europe to Middle East services at a glance

■ Mainliner & Shuttle Services

Additional feeder port coverage available, see geographic cover maps

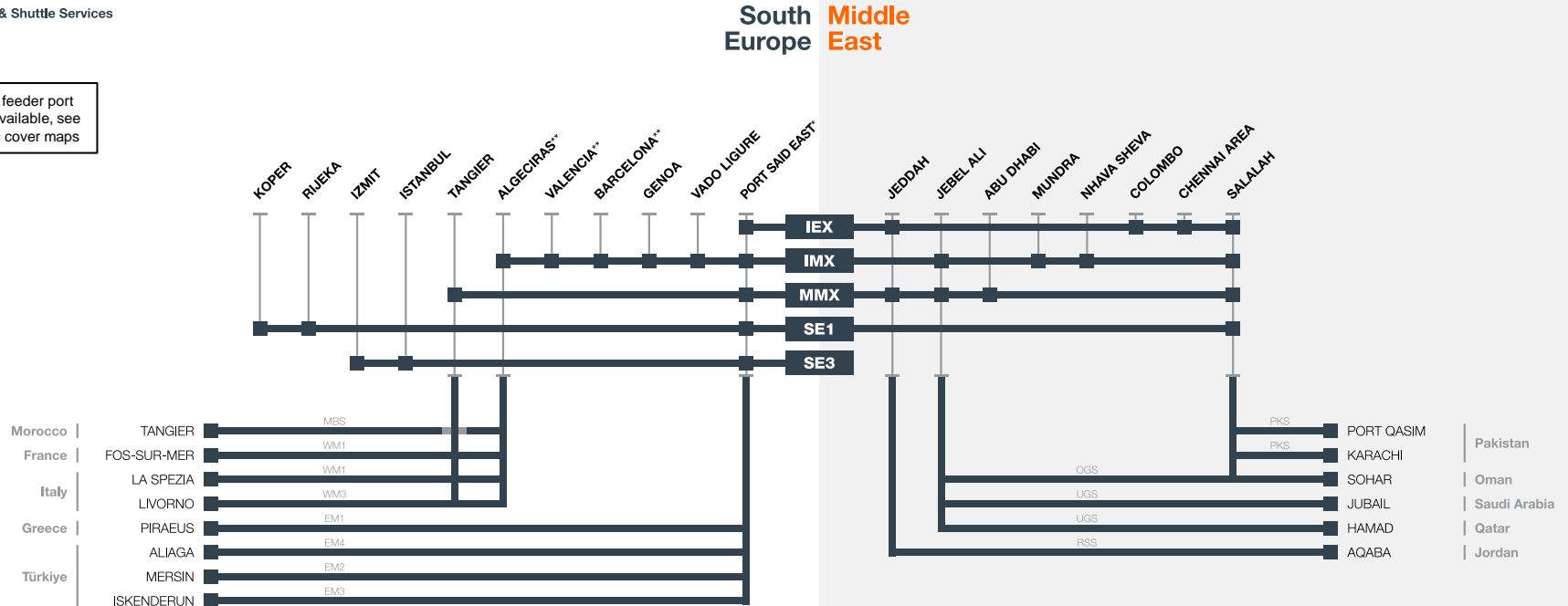

All displayed Services are part of the Gemini Cooperation
 * Certain Port Said East EB Calls will be shifted to Damietta during 2025
 **Transpacific & Latin America connected via West MED HUB

Middle East - Mediterranean

Service Profile IMX

Gemini Cooperation Service

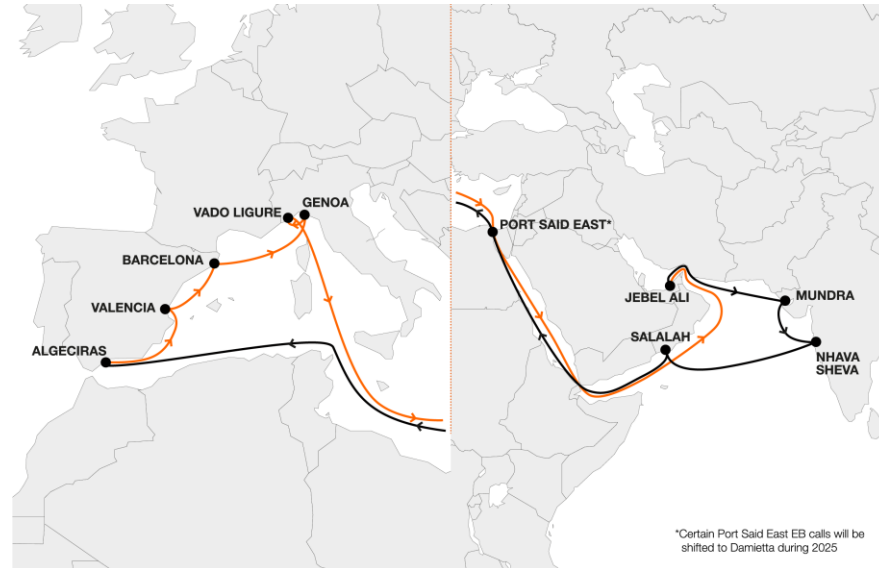

KEY SERVICE VALUE PROPOSITION

- Key service for connections from the West Mediterranean to the Middle East and West India via the Suez Canal
- Connection especially relevant for sensitive and high value cargo, e.g. reefer, OOG and break-bulk cargo
- Additional coverage of Jebel Ali (AE), Salalah (OM), Mundra (IN) and Nhava Sheva (IN) next to IOS

IMPORTANT CONNECTIONS

- Shuttles via Salalah (OM) allow connections out of Pakistan
- Shuttles from Algeciras (ES) connect to Fos-sur-Mer (FR)
- Shuttles from and to the Indian market enable fast and efficient transit to Türkiye, Levant and Greece plus Black Sea markets covered via additional feeders from Port Said East (EG)

Middle East - Mediterranean

Service Profile MMX

Gemini Cooperation Service

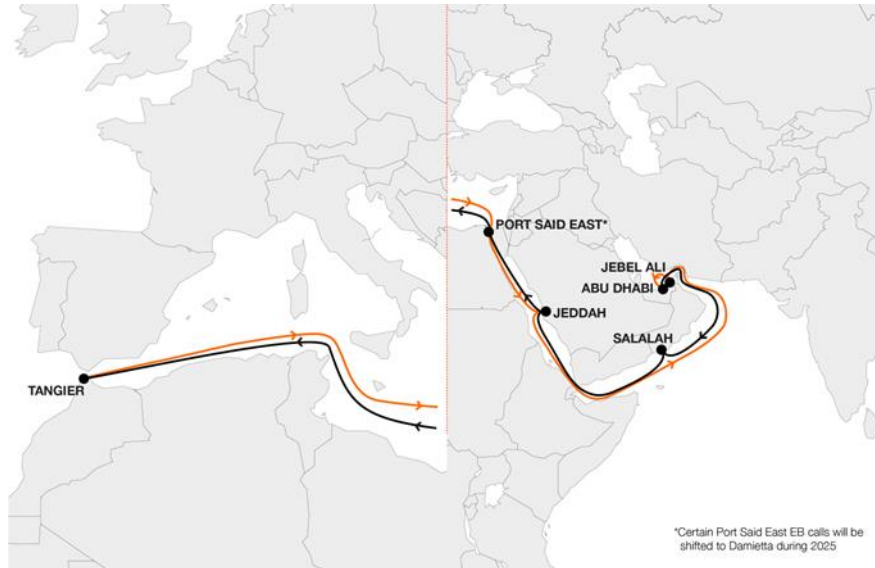

KEY SERVICE VALUE PROPOSITION

- Key service for connections from the Mediterranean and the Middle East to Tangier (MA) via the Suez Canal
- Serving the markets of Africa, US East Coast and Latin America through a direct connection to Tangier (MA)

IMPORTANT CONNECTIONS

- Mainline SSY's to North and South America through the connection in Tangier (MA)
- Shuttle network in Jebel Ali (AE) and Port Said East (EG) allows connection from the Arabian Gulf to Türkiye
- Several connection options from the Arabian Gulf and Red Sea, e.g. into Pakistan through shuttles via Salalah (OM)

Agenda

- | | | |
|-----------|---|-----------|
| A. | Hapag-Lloyd East-West Service Network at a Glance | 2 |
| B. | Trade Overview Asia - Europe | 7 |
| C. | Trade Overview Atlantic | 28 |
| D. | Trade Overview Transpacific | 52 |
| E. | Trade Overview Middle East | 73 |
| F. | Overview Shuttle Network and Intra Regional Trades | 87 |

The joint network uses a hub and spoke model to make it much more reliable and resilient, with fast connectivity

NETWORK PRINCIPLES

- **Setup** with 2-3 main port calls per region including strategic hubs enable shorter round voyage times and better reliability
- **All hub terminals are carefully selected for top quality and reliability plus mostly owned and/or controlled** by Hapag-Lloyd or Maersk
- Hub & Spoke with multiple shuttles provide **wide coverage** and **fast connections**
- **Synchronized** connections from **mainliners** to **mainliners** and **to shuttles** significantly reduce dwell times

This network is much more **reliable** and **interconnected** than traditional setups, increasing **resilience** against external effects. We will reach this through a combination of streamlined port calls, controlled hubs and dedicated shuttle services.

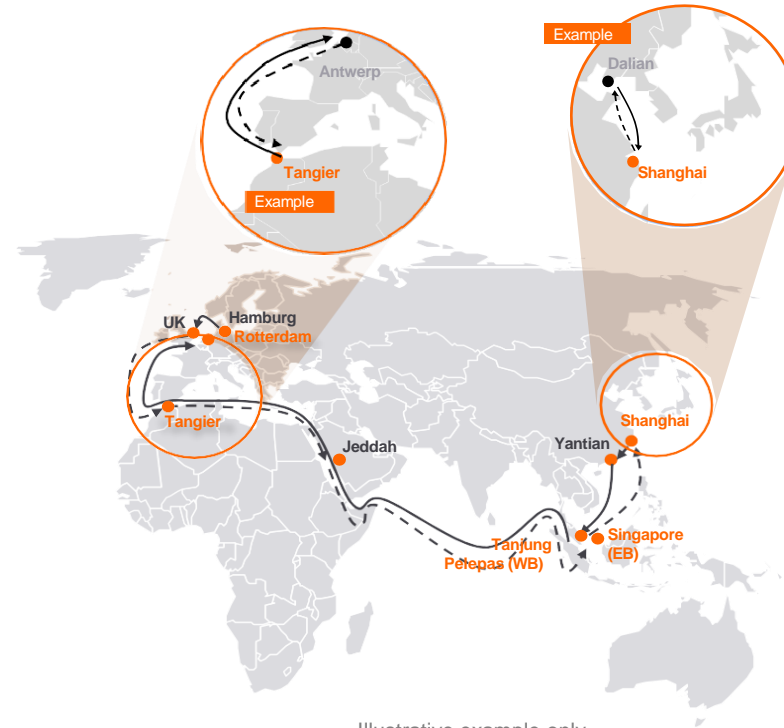

Illustrative example only

Our dedicated shuttles complement our network with fast and reliable connections within the regions and serve Intra Regional Trades

HIGHLIGHTS

- **Extensive shuttle network** covering Europe, Asia, Middle East and North America
- **Shuttles** are dedicated to **serve** the **Gemini Cooperation partners**
- **Shuttles** are **deployed by the Gemini Cooperation partners**
- Shuttle network offers **competitive solutions** for **Intra Regional Trade cargo**
- **Shuttles will connect to selected other Hapag-Lloyd services** that are not part of the Gemini Cooperation

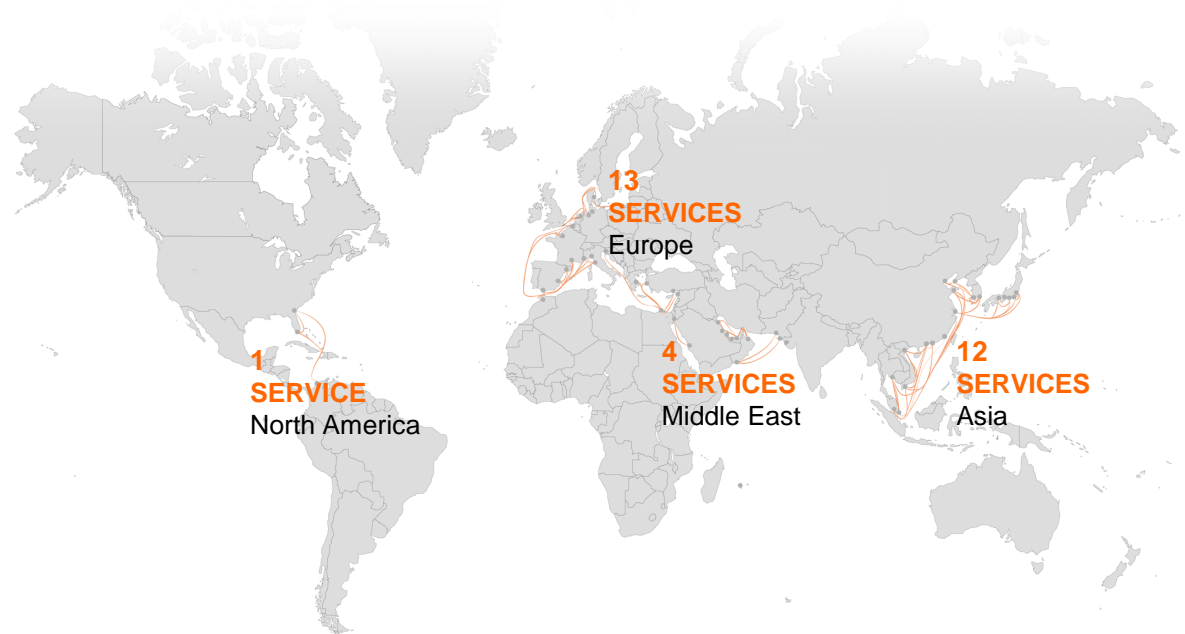

Our feeder network will enhance our broad connectivity in specific markets

Complementing Feeder Network

- Smaller sized vessels operated by either Hapag-Lloyd or strategic suppliers
- Extension of our existing hub and shuttle port coverage ensuring seamless connectivity in specific markets
- Next to our mainliner and shuttle network, an integral part to support our customers cargo planning globally
- Supporting the optimization of routes and vessel deployments to contribute further to our reliability goals

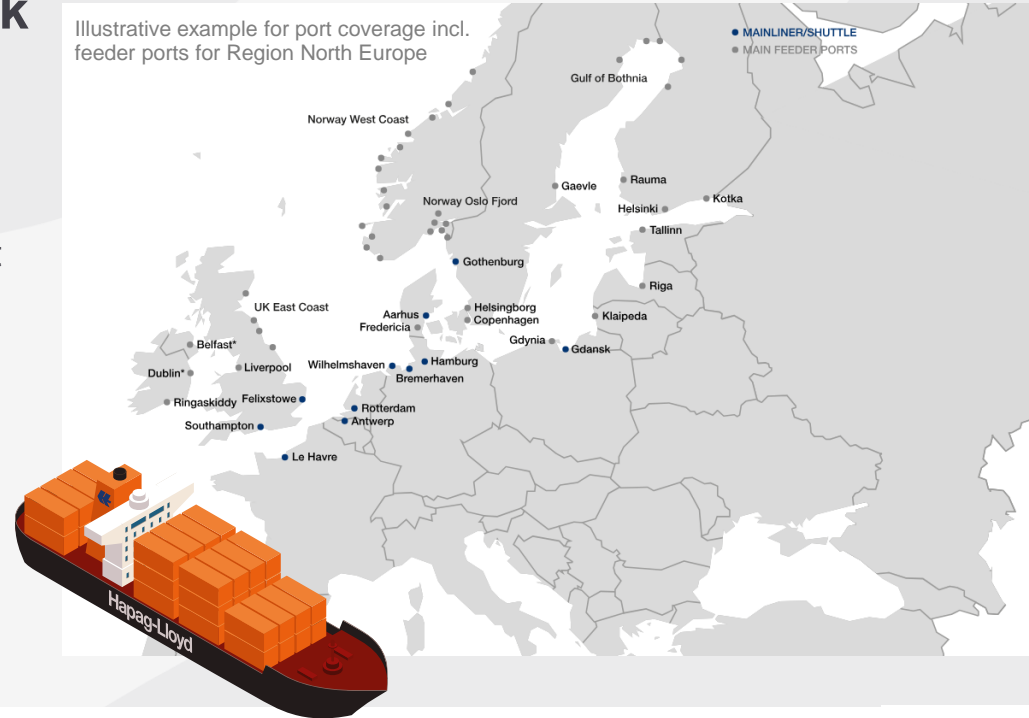

Europe Shuttle & Feeder Services

Preliminary

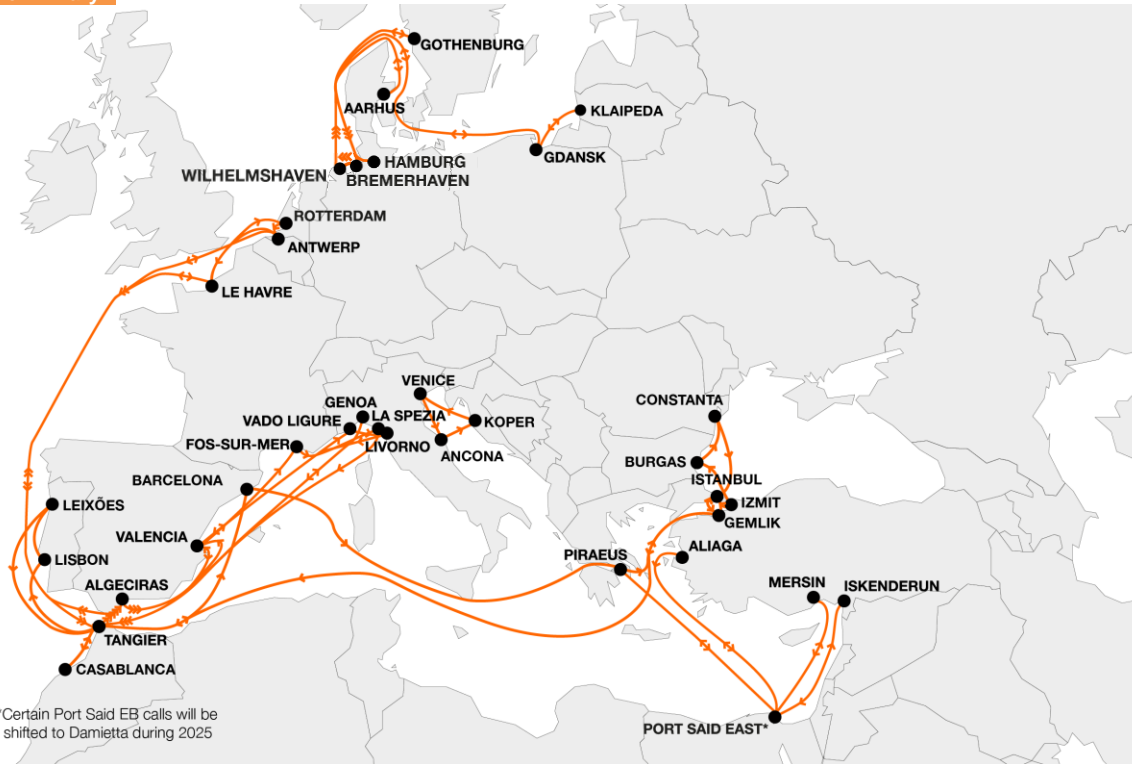

KEY FACTS

17 shuttles & feeders

35 ports

28 vessels

3.8 TTEU Ø vessel size

3 calls per shuttle & feeder
(Ø)

Europe Shuttle & Feeder Services (1/3)

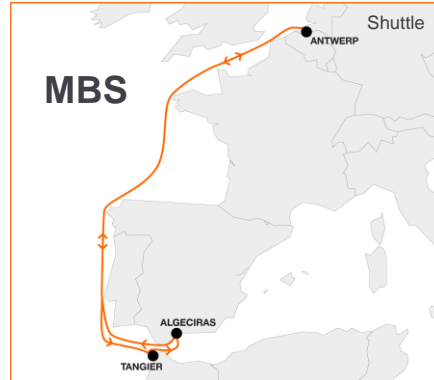

Europe Shuttle & Feeder Services (2/3)



Europe Shuttle & Feeder Services (3/3)



Middle East Shuttle & Feeder Services

Preliminary

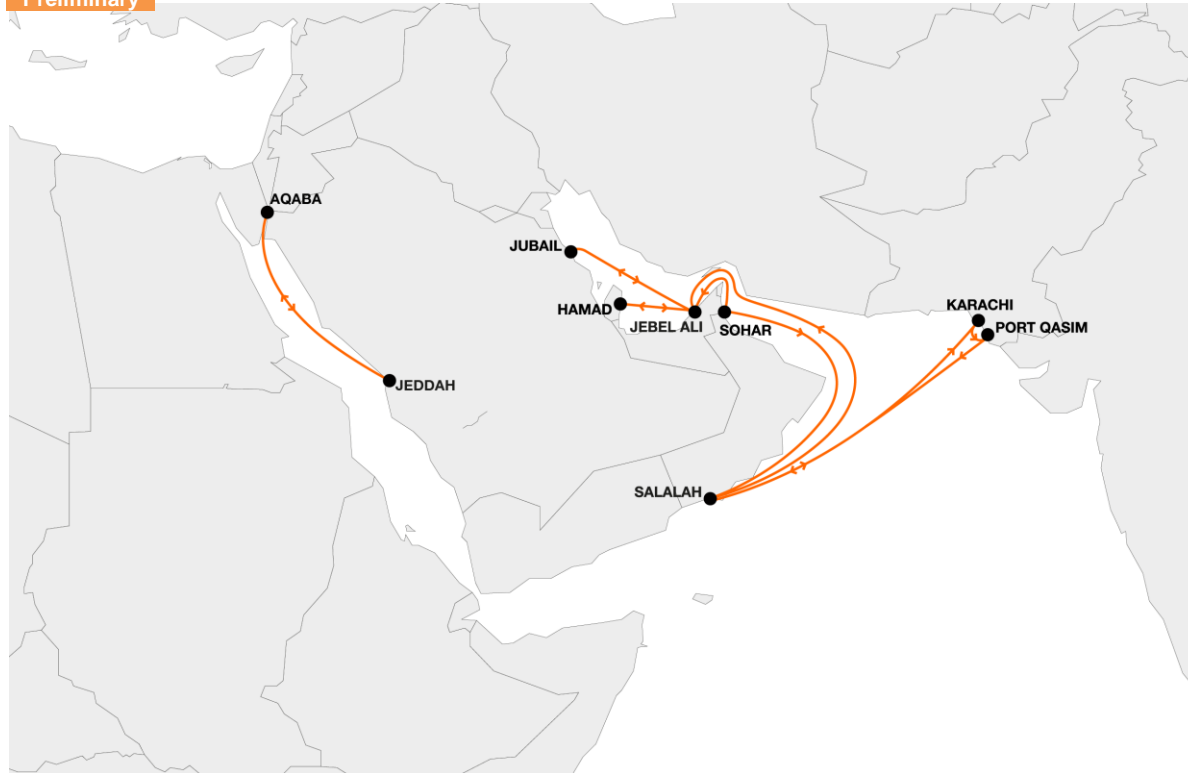

KEY FACTS

6 shuttles & feeders

14 ports

10 vessels

4.9 TTEU Ø vessel size

3 calls per shuttle & feeder
(Ø)

Middle East Shuttle & Feeder Services

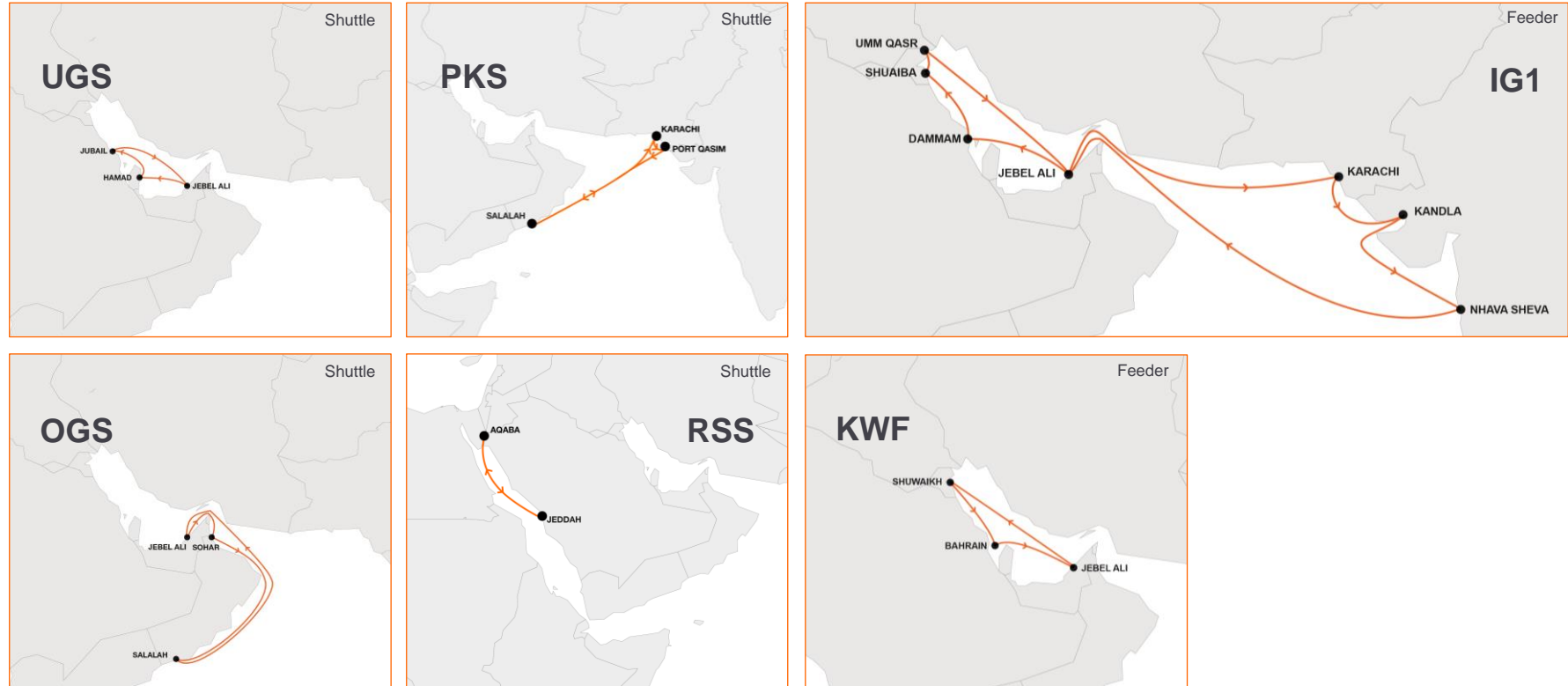

Asia Shuttle Services (1/2)

Preliminary

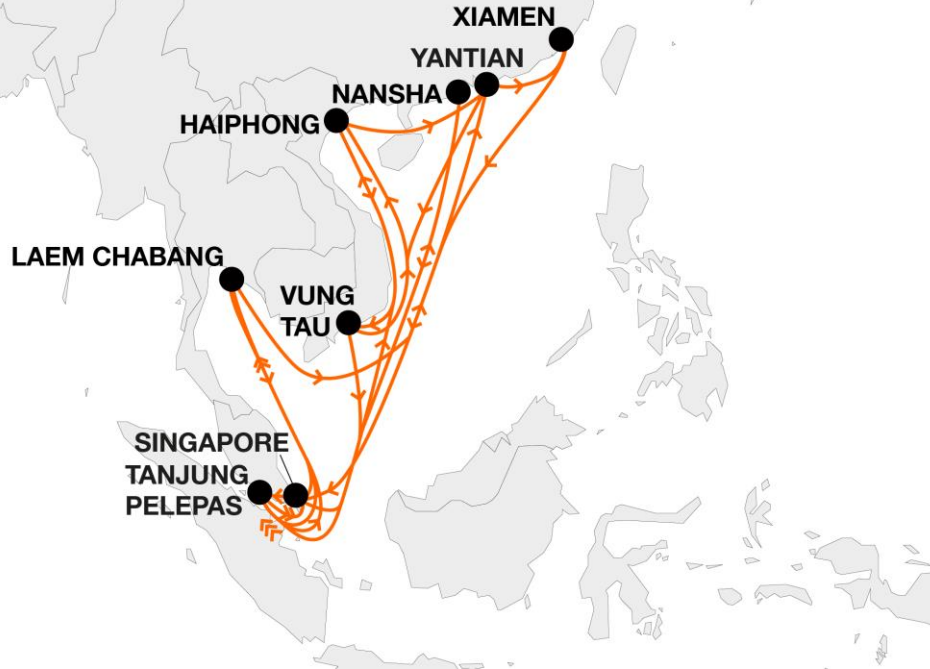

KEY FACTS

12 shuttles

19 ports

30 vessels

5 TTEU Ø vessel size

4 calls per shuttle (Ø)

Asia Shuttle Services (2/2)



KEY FACTS

12 shuttles

19 ports

30 vessels

5 TTEU Ø vessel size

4 calls per shuttle (Ø)

Asia Shuttle Services (1/2)

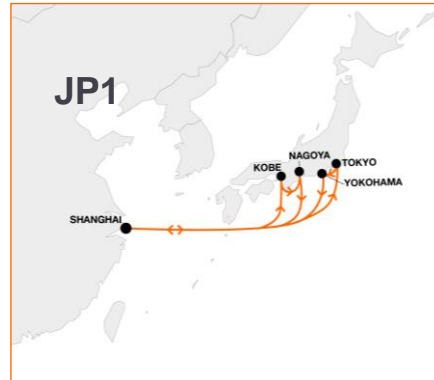

Asia Shuttle Services (2/2)



North America Shuttle

Preliminary



KEY FACTS

1 shuttle

3 ports

2 vessels

3.0 TTEU Ø vessel size

3 calls per shuttle (Ø)

FOLLOW OUR STORY



Thank you for your attention!



DISCLAIMER

Disclaimer

This presentation contains forward-looking statements that involve a number of risks and uncertainties. Such statements are based on a number of assumptions, estimates, projections or plans that, by their nature, are subject to significant risks, uncertainties and contingencies. Actual results may differ materially from the Companies' forward-looking statements and expected results.